

## MANUAL – INSTALLATION

---

# Prodigy

Prodigy® Digital VAV Diffusers

v200 – Issue Date: 12/30/21

© 2021 Price Industries Limited. All rights reserved.

**PRICE** | VAV  
DIFFUSERS

# PRODIGY® - DIGITAL VAV DIFFUSERS

## TABLE OF CONTENTS

### Product Overview & Installation Instructions

General Description .....	1
Installation into Ceiling .....	1
Power Supply to Master .....	2
Drone Power Supply Connection.....	3
Model Nomenclature .....	4
Model Configuration / Setpoint Adjustment .....	6
Auxillary Heat .....	6
Optional Accessories.....	7
Price Power Module Optional Accessory .....	7
TR115 / TR277 Transformer Optional Accessory.....	8
Prodigy Pressure Relief Collar Optional Accessory.....	8
Baffle Optional Accessory.....	9
Supply Air Temperature Sensing.....	9
Thermostat Installation .....	12

### Display Navigation

Initial Setup .....	13
Information Menu (LCD Stats only).....	14
Service Menu (LCD Stats only).....	15
Balancing Menu .....	16
VVT Menu (Pressure Dependant Mode) .....	17
Setpoint Menu (Setpoint Limits and Temperature Units).....	18
Input Menu (Supply Air Temp and Neutral Mode) .....	19
Output Aux Binary Menu .....	20
Output Analog Menu.....	21
BACnet Menu (BACnet Addressing Setup) .....	22
Stat Setup Menu.....	23
Display Options Menu .....	24

### Native BACnet Network Interface Optional Accessory

BACnet Module .....	25
BACnet Wiring .....	26
Network Wire Specifications .....	27
BACnet Service Menu .....	28
BACnet Module .....	27
BACnet Networking and Setup .....	30
Setting the Device Instance (Coupled MAC and DI) .....	31

### Maintenance

Troubleshooting Guide .....	31
Master Specifications .....	33
Drone Specifications .....	33

## SUPPORT ▼

Having difficulty installing this product?  
Price is here to help.

### Application Support

Phone: 510.785.0510

Email: [vavdiffusers@priceindustries.com](mailto:vavdiffusers@priceindustries.com)

# PRODIGY® - DIGITAL VAV DIFFUSERS

## PRODUCT OVERVIEW & INSTALLATION INSTRUCTIONS

### General Description

Prodigy diffusers are digital VAV diffusers with built-in electric motor and controller providing VAV cooling and VAV heating. The damper modulates open and close to vary the air flow (warm or cool) into the room in response to room temperature. Master models have onboard controls, while the drone model imitates the master.

### Installation into Ceiling

Prodigy is available in four different geometries: square, round, swirl, and linear slot. Round inlets for connection to supply ductwork are standard on most models. Various border styles are available to suit most ceiling types. Please refer to individual model submittals for more details.

When installing units, make sure construction debris does not enter units or duct system.

1. Inspect the carton for damage before opening. Notify carrier if external damage exists. Submit all claims for shipping damage to the carrier.
2. Move diffusers (in cartons) to installation area. Note any unit identification.
3. Remove cardboard box and insert. Recycle packaging material.
4. Install in ceiling grid. Install T-bar support wire close to each corner of unit. Make sure that only wire suspended T-bars are used to support unit weight. Do not use screws or drill holes in the areas marked "No Holes or Screws".
5. Connect and secure the supply duct to the collar. Flexible duct should NOT be formed in a centerline radius of less than 1½ times the duct diameter.
6. Connect wall thermostat (see thermostat options pg 4)
7. Connect supply power (see supply power options (pg 2).

FIGURE 1 ▼

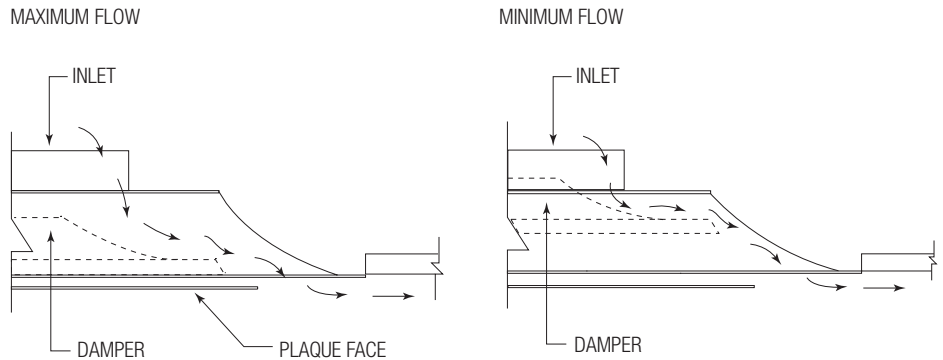

FIGURE 2 - TYPE 1 SURFACE MOUNT ▼

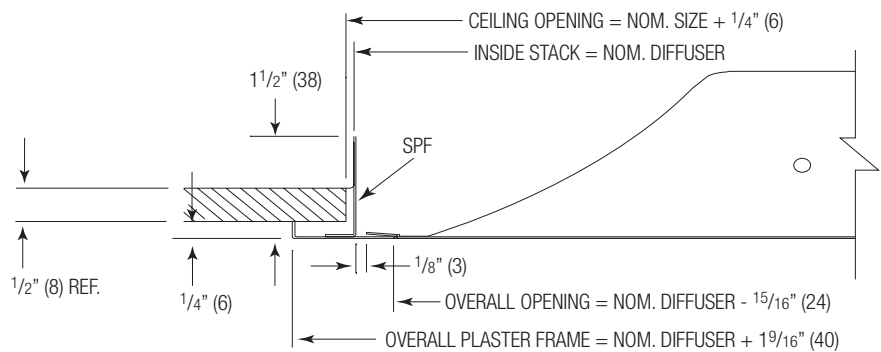
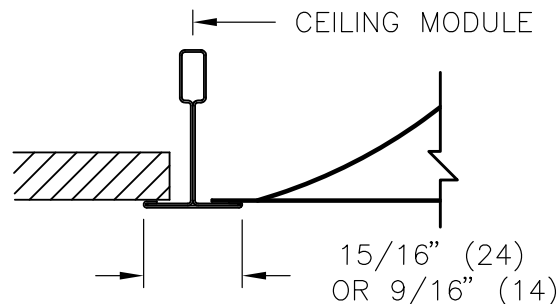

FIGURE 3 - TYPE 3 T-BAR ▼



MORE BORDER TYPES AVAILABLE. PLEASE SEE INDIVIDUAL MODEL SUBMITTALS FOR MORE DETAILS

# PRODIGY® - DIGITAL VAV DIFFUSERS

## PRODUCT OVERVIEW & INSTALLATION INSTRUCTIONS

### Power Supply to Master

All Prodigy Master units require a 24 VAC power supply and each draws 3.0 VA. There are three options for power:

#### 1. Field Supplied 24 VAC

Connect 24 VAC and common lines to optional TP (Terminal Plug). (One TP is supplied as a standard item in the AUX HEAT output, and may be relocated for power input if not required for AUX HEAT.)

#### 2. TR115 / TR277 20 VA Transformer

Master units supplied with transformer mounted to Prodigy Diffuser require field connection of primary power supply and grounding. Secondary power supply will be factory connected to pluggable 24 VAC PWR terminal block.

See Mounting/Installation instructions on Page 9 if transformer is shipped separately.

#### 3. Price Power Module (PPM)

(See Mounting/Installation Instructions on Page 8)

Use a C35 (35' Plenum rated snap-in cable) to connect power output jack on PPM to power input jack on Prodigy.

Additional Prodigy Master Units can be powered by daisy-chain connections if optional CSJ (Splitter Jack), is used. See Page 8 for limitations.



### NOTE ▾

HOT and COMMON 24 VAC polarity is critical and must be consistent. 24 VAC COMMON must be EARTH ground in field to ensure proper BACnet network communication.

FIGURE 4 - MASTER JUNCTION PANEL ▾

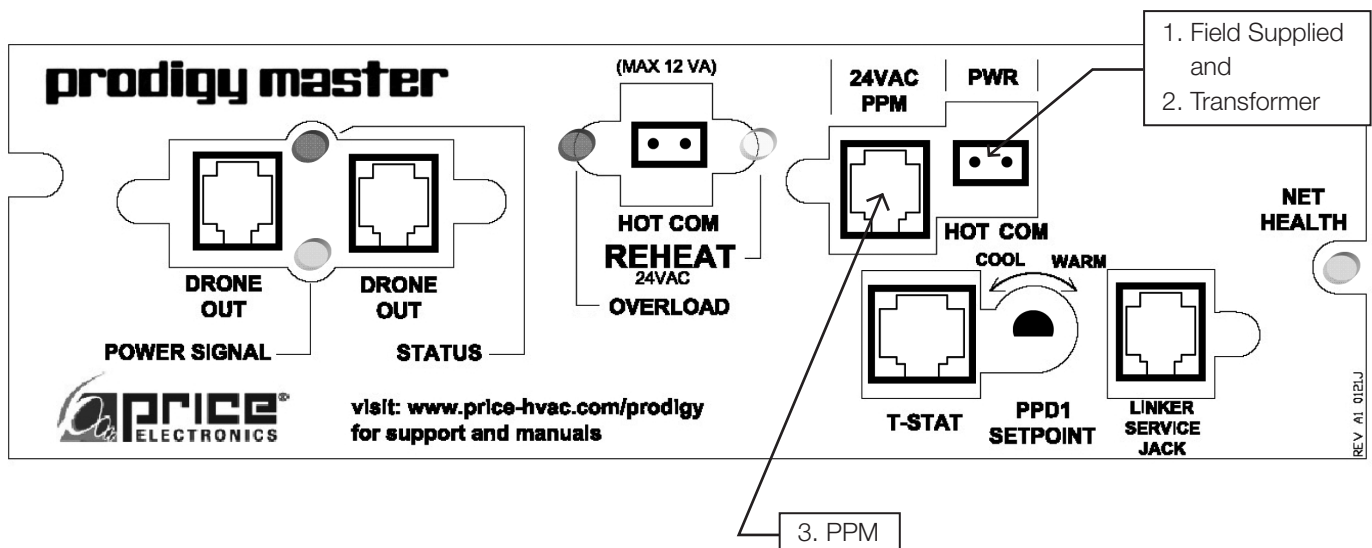

### Normal Operation

- Power Signal (green) 'On'
- Status (red) 'Flashing'
- Reheat (orange) 'On' when heat on
- Overload (red) 'Off'
- Net Health (green) 'Flash' with BACnet

# PRODIGY® - DIGITAL VAV DIFFUSERS

## PRODUCT OVERVIEW & INSTALLATION INSTRUCTIONS

### Drone Power Supply Connection

#### PPDD

(See Figure 3, Figure 4, Figure 5, Figure 6)

- Unit has two RJ12 Jacks to make daisy chain connections for 24 VAC and 2-10 VDC control signal from master unit.
- C35 (35' plenum rated cable) supplied with RJ12 modular plugs at both ends. Use cable to connect unit with DRONE OUT (Fig. 4) on Prodigy Master (PPD1, PPD2 or PPD3) or previously connected PPDD using a free Drone output Drone Jack (Fig. 5). Cable length may be extended by using a CC (cable connector) for longer runs.
- A maximum of five PPDDs can be supported by one Prodigy Master (PPD1, PPD2 or PPD3).
- Each PPDD draws 3.0 VA.

FIGURE 5 - DRONE JUNCTION PANEL ▼

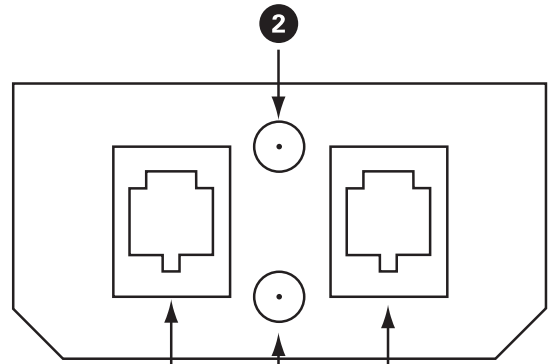

#### Legend

- 1 DRONE INPUT / OUTPUT
- 2 RED LED (2-10 VDC DRONE SIGNAL)
- 3 GREEN LED (24 VDC POWER)

FIGURE 6 - LAYOUT EXAMPLES ▼

PPM 115 / 277 POWER SUPPLY (6 MAX DIFFUSERS PER JACK. 15 MAX DIFFUSERS PER PPM)

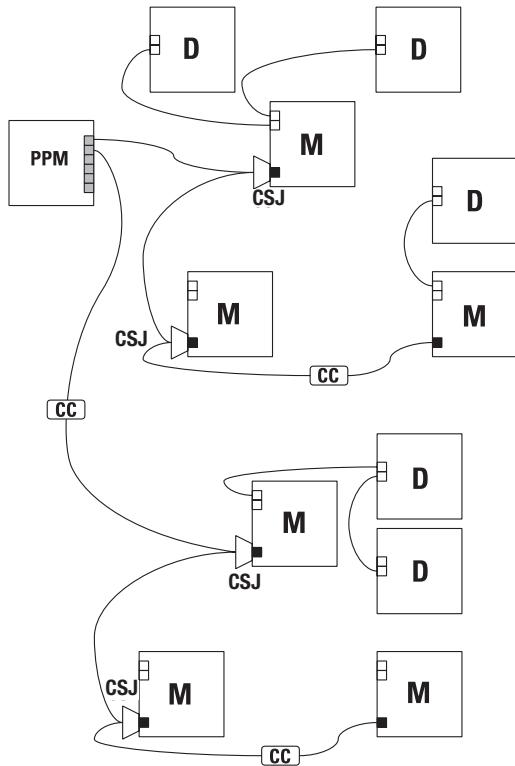

- M = MASTER
- D = DRONE
- USE C35 CABLES
- POWER JACK
- DRONE JACK

FIGURE 7 - LAYOUT EXAMPLES ▼

TR115 / 277 POWER SUPPLY

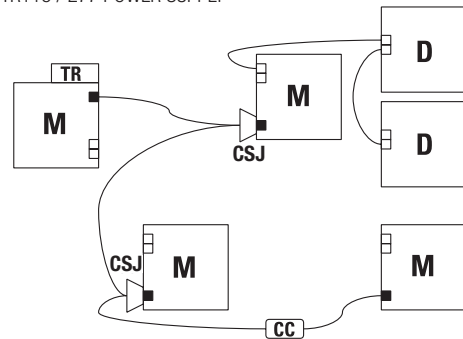

- M = MASTER
- D = DRONE
- USE C35 CABLES
- POWER JACK
- DRONE JACK

# PRODIGY® - DIGITAL VAV DIFFUSERS

## PRODUCT OVERVIEW & INSTALLATION INSTRUCTIONS

### Thermostat Options

The Prodigy Master uses a wall thermostat to accurately sense room temperature in both cooling and heating modes. Each thermostat comes complete with a 35ft plenum rated cable for connection to the Prodigy Master.

The thermostat is available in six options:

- Room Sensor (Blank Face).
- Dial Thermostat
- LCD Thermostat
- LCD Thermostat with motion sensor for occupancy
- LCD Thermostat with CO2 and humidity sensors
- Wireless Thermostat

The LCD thermostats are used to adjust set points, display room temperature, and configure the different parameters of the diffuser.



**NOTE** ▼ When using the Room Sensor or Dial Thermostat order a LCD-SET (minimum of one per project) to configure the diffuser.

### Thermostat Adjustment

VAV Cooling, VAV Heating - Connecting a wall mounted T'stat activates the Prodigy. Connect the T'stat to Prodigy using a supplied NETC35 (35' plenum rated cable) by snapping one side of the plug into jack inside of thermostat, and the other side into the T'Stat In jack. Setpoint is adjusted using the wall mounted sensor.

See page 10 and 11 for more thermostat details.

**FIGURE 8 - DRONE WIRING DIAGRAM ▼**

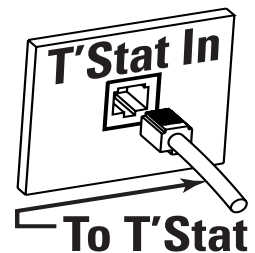
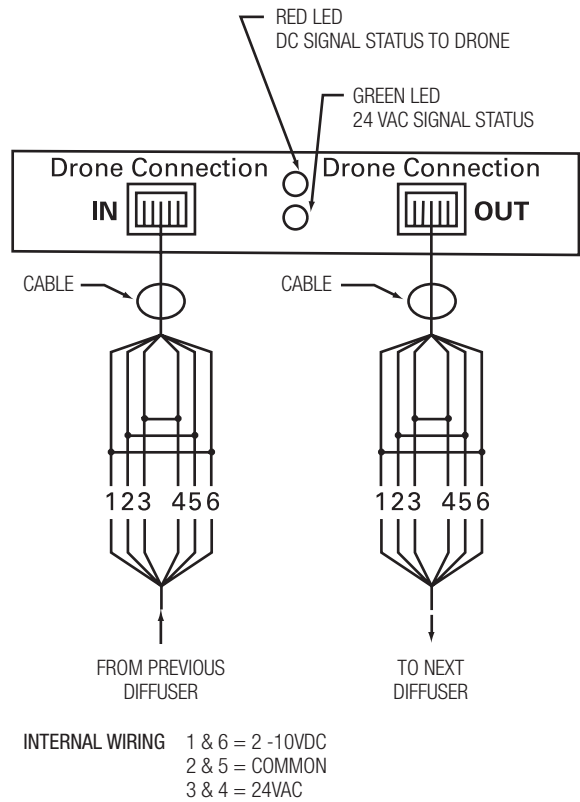

ROOM SENSOR    DIAL THERMOSTAT    LCD THERMOSTAT    LCD THERMOSTAT WITH MOTION SENSOR    LCD THERMOSTAT WITH CO2 AND HUMIDITY    WIRELESS THERMOSTAT

# PRODIGY® - DIGITAL VAV DIFFUSERS

## PRODUCT OVERVIEW & INSTALLATION INSTRUCTIONS

### Prodigy® Series Drone Unit

Drone units contain actuators and control circuitry to respond to signals from the master unit. The damper mechanism is synchronous with the master unit. Up to five drones can be supported by one master.

The geometry of the Master and Drone do not need match. The four different Prodigy geometries (square, round, swirl, and linear slot) can be interchanged between Master and Drone.

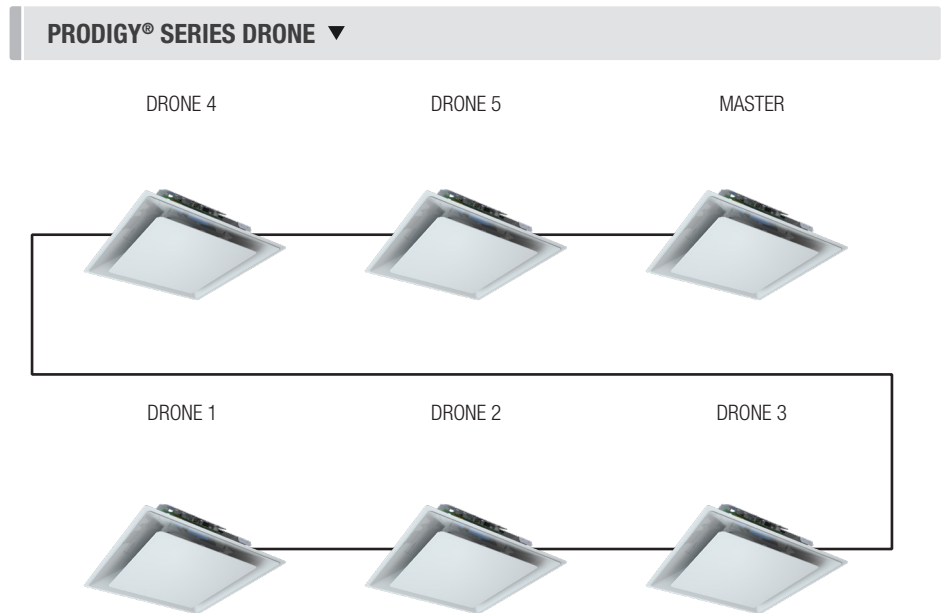

### Balancing

To correctly balance a VAV diffuser, set the maximum flow, the diffuser must be in the 100% open position. The Prodigy diffuser may be opened to 100% by:

- Accessing the override open command using the menus available on the LCD thermostat  
>Service Menu >Balancing >Dpr Override >Goto Full Open (see Balancing Menu page 16)
- or, if the Prodigy is on a BACnet network, setting AV25 to 6 (Damper Open 100%)

Maximum flow from the diffuser can also be limited by accessing the maximum damper position by:

- Accessing the damper maximum settings using the menus available on the LCD thermostat  
>Service Menu >VVT >Dpr Cool Max or >Dpr Heat Max (see VVT Menu page 17)
- or, if the Prodigy is on a BACnet network, setting AV22 Cool Max and AV24 Heat Max

To set the minimum flow from the diffuser, limit the minimum damper position by:

- Accessing the damper minimum settings using the menus available on the LCD thermostat  
>Service Menu >VVT >Dpr Cool Min or >Dpr Heat Min (see VVT Menu page 17)
- or, if the Prodigy is on a BACnet network, setting AV21 Cool Min and AV23 Heat Min

# PRODIGY® - DIGITAL VAV DIFFUSERS

## PRODUCT OVERVIEW & INSTALLATION INSTRUCTIONS

### Auxiliary Heat

All Prodigy Master control units will provide a 24 VAC pulsed output signal for supplemental auxiliary heating. Two terminals are located on the junction board for this purpose (**Figure 9**). The signals can be wired to an intermediate relay to control a auxiliary heating system.

The internal reheat relay is limited to 12 VA and should not be used to directly drive valves or radiant panels. It is intended to switch power to the primary coil of an intermediate relay (see **Figure 9**). **CAUTION:** The number of Drones supported by the Master must be reduced for each 3VA used to power the Aux Heat. **CAUTION:** The number of diffusers (Master and Drone) supplied by the PPM must be reduced for each 3VA used to power the Aux Heat.

### Three options of reheat algorithms are available:

1. **On/Off** - Acts more like a traditional thermostat and cycles least of all three options. Control is over a larger temperature band ( $\pm 20F$ ). Suitable for mechanical relay interface (24VAC, 12VA max).
2. **PDM** (default, if not specified) (Pulse Delay Modulation) - Reheat relay is on for a minimum of 2 minutes when required. OFF Cycle is proportional to heating requirement. Suitable for hydronic systems where entire system is flushed with hot water during each heating charge to ensure uniform heating. Electronic Solid State Relay interface recommended, but not required.
3. **PWM** (Pulse Width Modulation) - Reheat relay is on for a percentage of the duty cycle, proportionate to calculated heating load. Suitable for radiant panels and other electric heaters. Electronic Solid State Relay interface absolutely required - rapid pulse, 2 second cycle.

**NOTE:** Auxiliary heat option can be reconfigured in the field if necessary using LCD thermostat (Service Menu).

**FIGURE 9 - MASTER WIRING DIAGRAM** ▼

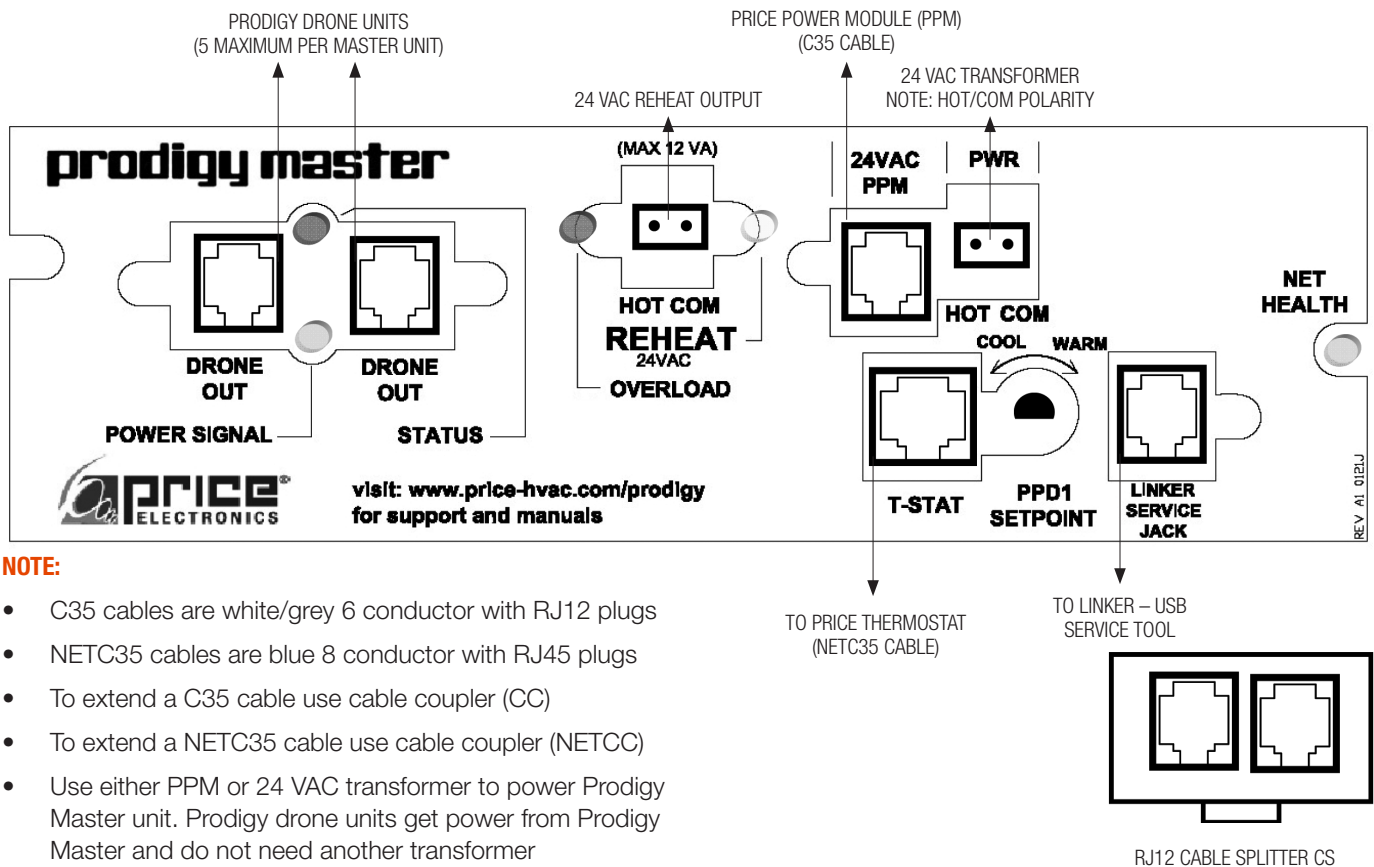

### NOTE:

- C35 cables are white/grey 6 conductor with RJ12 plugs
- NETC35 cables are blue 8 conductor with RJ45 plugs
- To extend a C35 cable use cable coupler (CC)
- To extend a NETC35 cable use cable coupler (NETCC)
- Use either PPM or 24 VAC transformer to power Prodigy Master unit. Prodigy drone units get power from Prodigy Master and do not need another transformer



# PRODIGY® - DIGITAL VAV DIFFUSERS

## PRODUCT OVERVIEW & INSTALLATION INSTRUCTIONS

### Price Power Module Optional Accessory

The Prodigy® Power Module (PPM) supports up to fifteen\* (15) Prodigy diffusers (Masters plus Drones). It provides the most economical and convenient method of powering multiple Prodigy diffusers because electrician time is minimized. Designed to be ceiling mounted, the enclosed 96 VA Class 2 transformer is offered for 120V, 240V, 277V and 480V primary voltage supply. Final power connections to the Prodigy diffusers are completed via plenum cables with RJ (Snap-In) plugs. Since the cables are all low voltage, commissioning or relocation of Prodigy diffusers is simple.

\*See **CAUTION** pg 6 if using Aux heat option.

### Features

- **96 VA Class 2 Transformer** (120 / 240/277/480 to 24 VAC) with breaker resettable overload protection.
- **6 parallel power jacks** each of which support up to 6 Prodigy units (or PIC controllers) - any combination of masters and associated drones. Overload indicator LEDs on each line light up if too many Prodigy diffusers (or PIC's) are connected or if there is a short in the cable.
- **Max 15 Prodigy diffusers** or PIC controllers per PPM
- C35 (35' plenum rated cable) with RJ plugs provides flexible and convenient power connection. One required for each master unit (order separately). Multiple cables can be connected by using a CC (Cable Connector) for longer runs. (Fig. 6 page 3.) 210ft maximum.
- CSJ Cable Splitters used to daisy chain power between masters. (Fig. 6 page 3.) 210 maximum.
- Power switch with indicator LED.

### Installation Instructions

1. Turn off power switch. Remove cover.
2. Secure box to surface in plenum using 3 mounting holes. Orientation irrelevant.
3. Supply power and ground to terminal per wiring diagram.
4. Replace cover.
5. Turn on power switch. Green LED indicates power

### Connecting a Prodigy Master to the PPM

1. Plug C35 power cable into an output jack on power module.
2. Plug other end of cable into power input jack of Prodigy Master Junction Panel. (Multiple C35 cables can be connected with CC - Cable Connectors for longer runs.) (Max two 35 ft cables)
3. Green Power LED and Red Drone Signal LED on Prodigy Master indicate proper connection.
4. An additional Master unit may be supported from second side of an optional CS (cable splitter) inserted into the

### PRICE POWER MODULE ▼

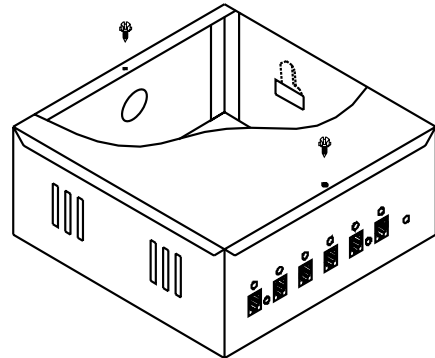

### PPM CONNECTIONS ▼

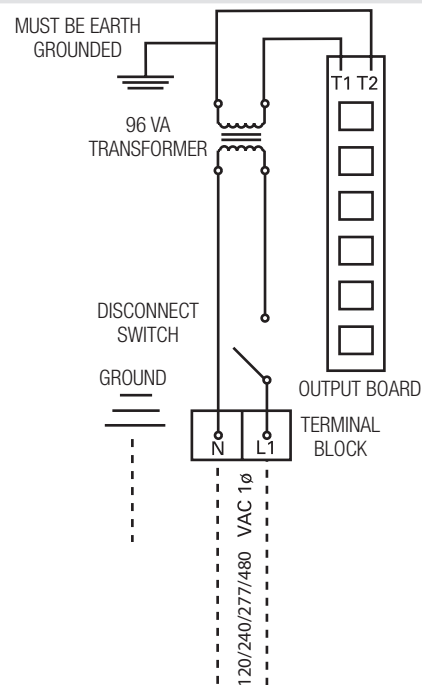

Prodigy Master power input jack. (see Fig. 6 page 3).

### Specification and Limitations

1. Total connected load not to exceed 96 VA (or 15 devices)
  - Each Prodigy unit (Master or Drone) draws 3.0 VA.
  - See **CAUTION** pg 6 if using Aux heat option.
2. Specification for each of the 6 output jacks:
  - 20 VA auto-reset thermal fuse with fault indicator LED.
  - Supports up to 6 Prodigy diffusers up to a maximum distance of 210' from the PPM
  - Supports only one mechanical relay (12 VA max.) for aux. heat output up to a maximum distance of 35'. (No limitation applies to electronic solid state.)

# PRODIGY® - DIGITAL VAV DIFFUSERS

## PRODUCT OVERVIEW & INSTALLATION INSTRUCTIONS

### TR115 / TR277 Transformer Optional Accessory

Optional **20 VA** transformer mounts to the junction bracket of Prodigy Diffuser. Support up to **6 Prodigy units** - any combination of masters and associated drones.

#### Installation Instructions

1. Remove lid from junction box.
2. Fasten to Prodigy junction bracket using two #8 screws provided.
3. Connect primary power supply and grounding.
4. Replace cover.
5. Connect secondary transformer leads to power jack of Prodigy (TP - Terminal Plug provided).

Additional masters units may be powered using C35 cables and CS (cable splitters) to daisy-chain power. (Fig. 7 page 3.)

### Prodigy Pressure Relief Collar Optional Accessory (Not Available for the PLD Prodigy Linear Diffuser)

The Prodigy® Pressure Relief Collar (PRC) slips over the Prodigy inlet to provide a simple and inexpensive method to control duct static pressure. The PRC's dual shutters are designed to gradually open in response to pressure in excess of approximately 0.25" w.g. and allow some of the supply air to escape into the return air plenum.

#### Installation Instructions

1. **The PRC is intended for use only in systems that have a non-ducted return air plenum.**
2. Mount PRC directly over Prodigy inlet, with shutters hanging down. Two mounting holes are provided for fastening with #8 sheet metal screws.
3. Mount ducting to top of PRC. A bead is provided on the top of the PRC as a stop for hard ducting. Flex duct may be banded below the bead providing it does not extend more than 1/2" below the stop bead as it will obstruct the proper operation of the shutters.
4. The PRC is shipped with shutters taped shut. **DO NOT REMOVE** the tape until the system is completely balanced. This will ensure that the balancer can provide maximum design cfm without excess air being relieved into the plenum. Premature removal of the tape may impair proper air system balancing.

### OPTIONAL 20 VA TRANSFORMER ▼

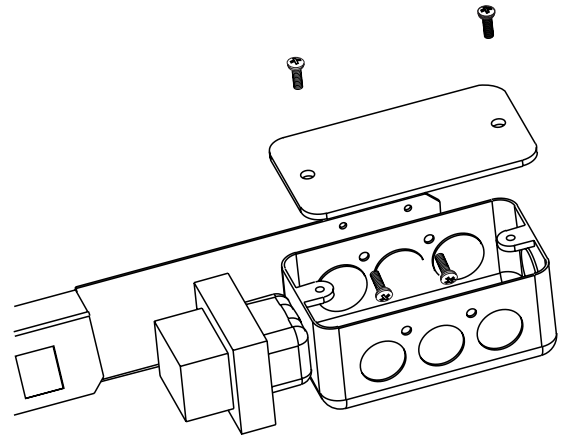

### INSTALLATION DIAGRAM ▼

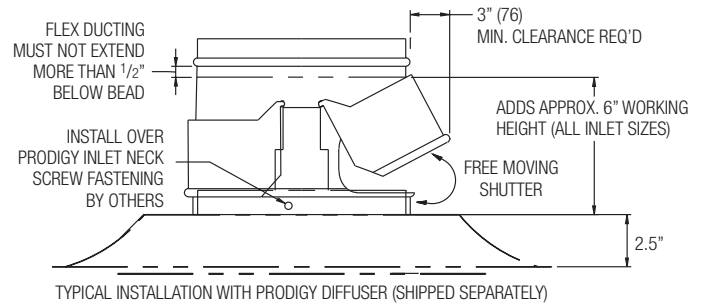

### PRESSURE RELIEF COLLAR ▼



# PRODIGY® - DIGITAL VAV DIFFUSERS

## PRODUCT OVERVIEW & INSTALLATION INSTRUCTIONS

### PPD Square - Baffle Optional Accessory

An optional baffle is available to provide 3-way and 2-way air patterns.

#### Installation Instructions

**CAUTION:** Adhesive tape bonds quickly. Price recommends a practice installation to locate the baffle BEFORE removing the tape pads.

1. Clean backside edge of plaque where baffle is to be installed.
2. With short flange of baffle facing away from opening, tilt top edge of baffle into opening on side of diffuser to be blocked. Short flange on baffle must face out.
3. Carefully align outer corner of reference tab A with corner of plaque.
4. Remove protective film from 3 tape pads.
5. Rotate bottom edge of baffle into opening until edge of flange is flush with edge of plaque.
6. Apply firm pressure at three tape tabs to secure baffle in place.

Additional openings can be blocked for 2-way air patterns using the same procedure.

#### BAFFLE ▼

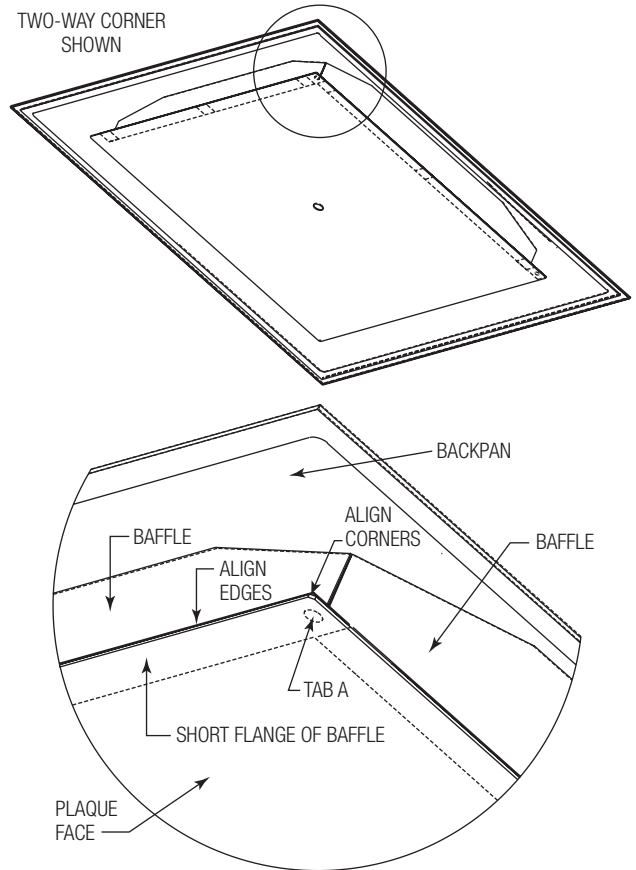

### Supply Air Temperature Sensing

All master units have a temperature sensor located near the inlet for automatic heating / cooling changeover.

For automatic changeover the Prodigy uses a dynamic neutral mode for optimal use of the supply air. Basically if the supply air can help the Prodigy meet the room set point it is used as such. For example if the supply air is 70F and the room temperature is 80F with a set point of 72F, the Prodigy will consider the supply air as cold and modulate appropriately. Please note however its typically difficult to cool a room with supply air temperatures above 60F.

Changeover and dynamic neutral mode is as follows:

1. **Heating Mode** - Supply air temperature warmer than room temperature by 2°F (1°C)
2. **Neutral Mode** - Supply air within 2°F (1°C) of room air
3. **Cooling Mode** - Supply air temperature 2°F (1°C) below room temperature)

If Dynamic neutral mode is not required user can force HOT and COLD switch points in the LCD thermostat menu. This method is not recommended, but is available for unique circumstances.

>Service Menu >Input >Neutral Mode >Dynamic -> Conventional (see page 19).

# PRODIGY® - DIGITAL VAV DIFFUSERS

## PRODUCT OVERVIEW & INSTALLATION INSTRUCTIONS

### Prodigy Thermostat Options

All thermostats are connected with a connection from the Prodigy to the back of the selected thermostat. Each thermostat has an RJ-12 Service Port on the bottom, used to connect an LCD-SETUP tool for balancing and parameter changes without having to access the penum.

- The Room Sensor Thermostat is powered from the controller.
- Measures room temperature.
- Set point can be adjusted from a hidden dial on the back of the T-Stat using a small flat head screw driver.
- Set point limits can be adjusted using the Setup Tool or, with BACnet option, over the BACnet network.
- Eliminated problem of unauthorized tampering to the thermostat.

#### ROOM SENSOR THERMOSTAT: PIC-TS-SENS ▼

1. Set point adjust from hidden dial on the back
2. Service Port



- The Dial Thermostat is powered from the controller.
- Measures room temperature & features a dial adjustment & an occupancy button.
- Set point limits can be adjusted using the Setup Tool or, with BACnet option, over the BACnet network.
- Simply use the adjustable dial for temperature adjustment.

#### DIAL THERMOSTAT PIC-TS-DIAL ▼

1. Dial Adjustment for Temperature
2. LED – 1 blink cooling mode, 2 – heating, 3 - neutral
3. Occupancy Override Button
4. Service Port

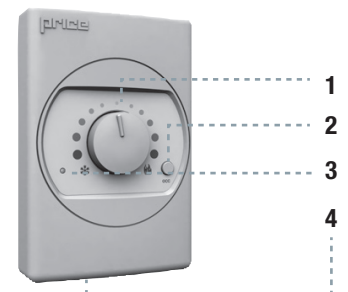

- The LCD Thermostat is powered from the controller and has a variety of features.
- Measures room temperature and features an LCD screen with push button day setpoint adjustment.
- Set point limits can be adjusted using the LCD thermostat or, with BACnet option, over the BACnet network.
- LCD Thermostat can also be used as a balancing tool for the Price Intelligent Controller system by simply connecting the RJ-45 cable to the back of the thermostat.

#### LCD THERMOSTAT: PIC-TS-LCD ▼

1. LCD screen for menu display
2. Menu Button
3. Increase and decrease push buttons for day temperature setpoint adjustment
4. Service Port

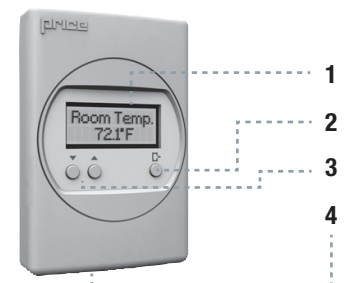

# PRODIGY® - DIGITAL VAV DIFFUSERS

## PRODUCT OVERVIEW & INSTALLATION INSTRUCTIONS

### Prodigy Thermostat Options (continued)

- The LCD Thermostat with Motion Sensor is powered from the controller and has a variety of features.
- This model measures room temperature, features an LCD screen with day Setpoint adjustment, and motion sensor with lighting control.
- Set point limits can be adjusted using the thermostat or, with BACnet option, over the BACnet network.
- The LCD Thermostat with Motion Sensor can be used as a balancing tool for the Price Intelligent Controller system by simply connecting the RJ-45 cable to the back of the thermostat.
- This thermostat can also be used as a motion sensor and enables the Unoccupied Mode (minimum damper position) when no motion is detected. It also has the capability to act as a lighting controller for occupied/unoccupied schedules.
- The LCD Thermostat with CO2 and Humidity is powered from the controller and has a variety of features.
- This model measures room temperature, features an LCD screen with day Setpoint adjustment, CO2 and Humidity sensing.
- Set point limits can be adjusted using the thermostat or, with BACnet option, over the BACnet network.
- The LCD Thermostat with CO2 and Humidity can be used as a balancing tool for the Price Intelligent Controller system by simply connecting the RJ-45 cable to the back of the thermostat.
- This thermostat can also be used to sense CO2 and enable the **purge mode** in the Prodigy diffuser.
- This thermostat can also be used to sense Humidity and can be monitored over the BACnet network.

- The Price Wireless Thermostat System provides both sensor inputs and a point of control for Price controllers.
- The System consists of 2 units:
- Wireless Remote T-Stat - Transmitter - Room sensor T-Stat with dial setpoint adjust, LED and push button.
- Wireless Base - Receiver - Unit with LCD and 3 push buttons.
- REMOTE T-STAT and BASE units talk between each other wirelessly in the 2.4GHz range (FCC and IC certified). BASE unit connects to main controller using the supplied NETC35 (35ft plenum rated CAT 5 cable with RJ 45 connectors) cable. No other connections are required.
- Set point limits can be adjusted using the Base (receiver) or, with BACnet option, over the BACnet network.

#### LCD THERMOSTAT W/MOTION SENSOR: PIC-TS-MOTION ▼

1. LCD screen for menu display
2. Menu Button
3. Increase and decrease push buttons for day temperature setpoint adjustment
4. Motion sensor allows for automatic detection of occupancy
5. Service Port – Linker connection

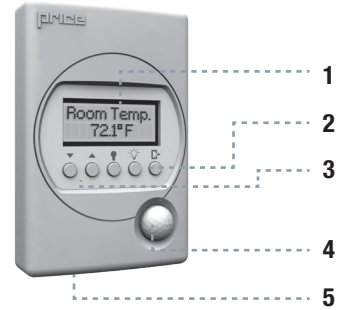

#### LCD THERMOSTAT W/CO2 AND HUMIDITY: PIC-TS-CO2H ▼

1. LCD screen for menu display
2. Menu Button
3. Increase and decrease push buttons for day temperature setpoint adjustment
4. CO2 sensor allows for automatic purge mode
5. Humidity sensor allows for monitoring
6. Service Port

\*Note: Requires connection to Master diffuser and additional connection of separate 24VAC supply power for CO2 measurement.

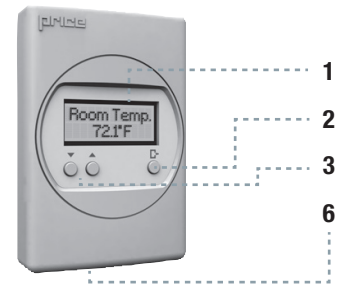

#### WIRELESS DIAL THERMOSTAT: PIC-TS-WIRELESS ▼

Base (Receiver) Mounted in Plenum

1. LCD Screen for menu display
2. Increase and decrease push buttons for day temperature setpoint adjustment
3. Service Port - Linker Connection
4. Menu Button

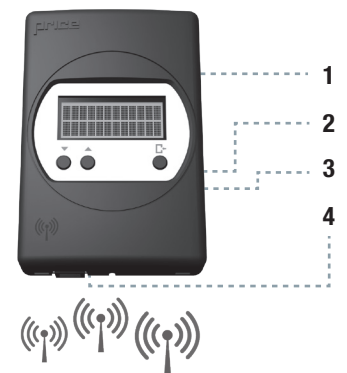

Remote (Transmitter) User Thermostat

1. Dial Adjustment for Temperature
2. LED – 1 blink cooling mode, 2 – heating, 3 – neutral
3. Occupancy Override Button
4. Service Port



# PRODIGY® - DIGITAL VAV DIFFUSERS

## PRODUCT OVERVIEW & INSTALLATION INSTRUCTIONS

### Thermostat Installation

#### General Description

The Prodigy thermostats are all physically the same size and mounting instructions will be typical.

#### Location

1. Thermostats must be mounted to a wall and wired to the controller via the supplied NETC35 (35ft plenum rated CAT 5 cable with RJ 45 connectors) cable. This cable plugs into the thermostat and the Prodigy with the ease of RJ-45 connections. Note: the cable run can be extended to 70 ft using a Price NETCC cable coupler and additional NETC35 ft cable.
2. Mount the required thermostat in a place that is convenient for the end user, but the following should be taken into consideration:
  - Do not mount a thermostat in direct sunlight i.e. across from a window where heat can alter the temperature reading.
  - Should not be installed on an outside wall.
  - Keep away from hot equipment like computers, monitors and heaters etc.
  - Ensure nothing will restrict vertical air circulation to the thermostat (Do not cover).
  - Ensure wall is not pressurized! Hot/cold air from a pressurized wall will direct blow onto the thermostat's temperature sensor causing 'bad' readings.

#### Installation

1. The back plate on each thermostat is removable and can be mounted to a standard electrical box or directly to drywall using anchors supplied by others.
2. Run the NETC35 cable through the center hole in the plate. Connect the cable to the thermostat, then secure the thermostat onto the wall plate inserting top portion of the thermostat first, then snapping the bottom half in.
3. All thermostats will come equipped with a 0.050" Allen key for the set screw at the bottom.



#### TECH TIP ▼

Careful thermostat installation will reduce field issues! **Do not twist or kink the blue NETC35 thermostat cable.** Damaged cables are difficult to troubleshoot!

#### SURFACE MOUNT DETAIL ▼

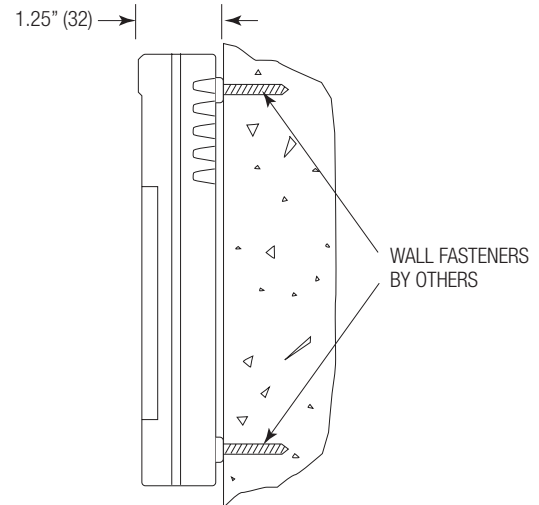

#### NETC35 35 FOOT PLENUM RATED CABLE - INCLUDED ▼



# PRODIGY® - DIGITAL VAV DIFFUSERS

## PRODUCT OVERVIEW & INSTALLATION INSTRUCTIONS

### BACnet NETWORK OPTION

Native BACnet is available on each master Prodigy diffuser. See page 26 for more details

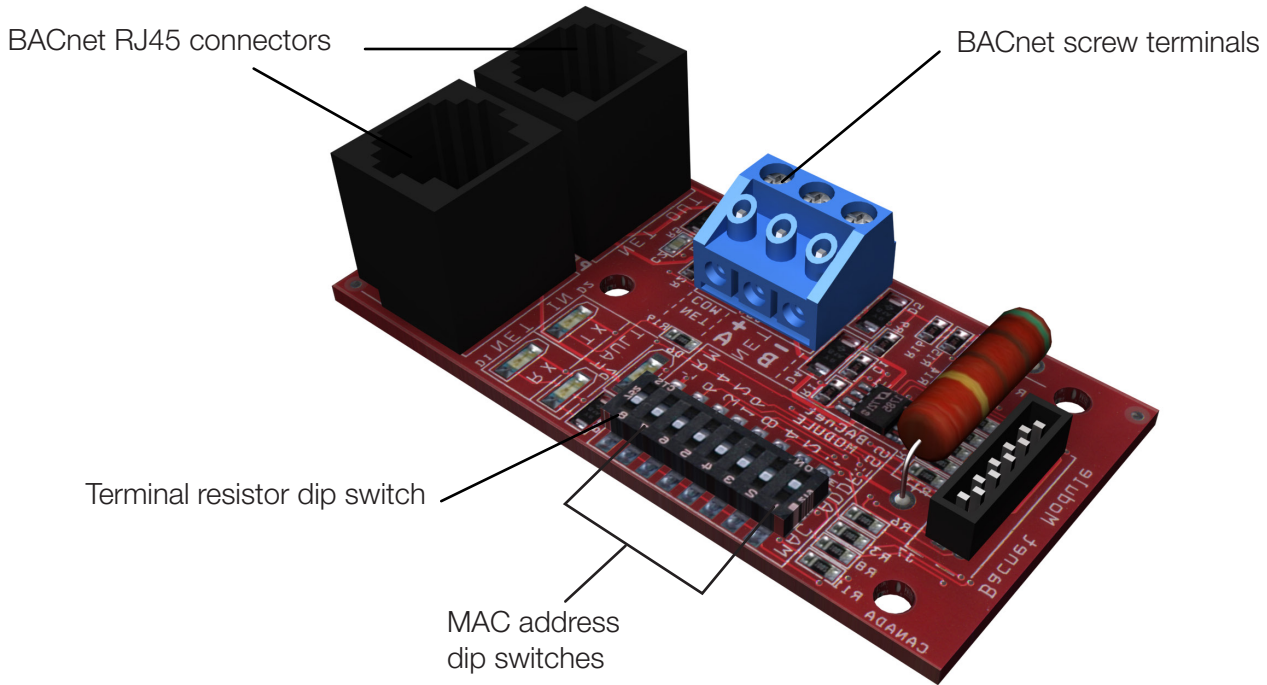

### DIFFUSER AIR FLOW MEASUREMENT OPTION

The DMS air flow measurement sensor may be added to the Prodigy to measure the air flow out of the diffuser. The DPS collar with SP300 multipoint sensor aligned with the flex elbow provides accurate measurement of air flow throughout the VAV diffuser operating range. In conjunction with the BACnet Interface option, the measured air flow from each diffuser is available to the BACnet network using object AV41.

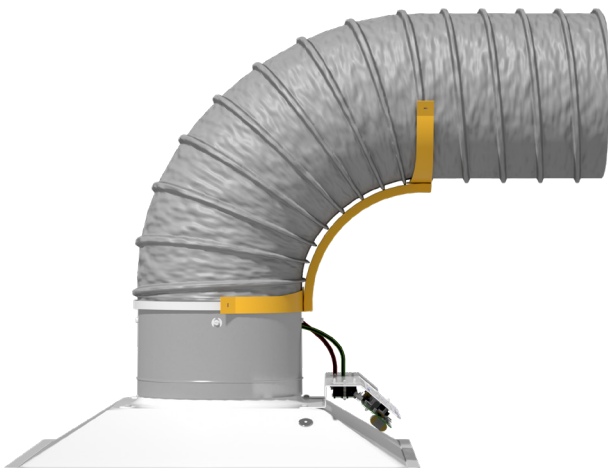

#### INSTALLATION

Align the pressure ports on the DMS collar to the control panel side of the diffuser. Align the flex elbow such that the duct enters from the control panel side of the diffuser. See DMS Manual for details.

#### CAUTION

For accurate flow measurement, the DMS must be installed with correct alignment between diffuser, DMS collar, and flex elbow.

# PRODIGY® - DIGITAL VAV DIFFUSERS

## DISPLAY NAVIGATION

### Initial Setup

LCD Thermostats Only

When the LCD thermostat is powered from the Prodigy, it will display the following information on power up:

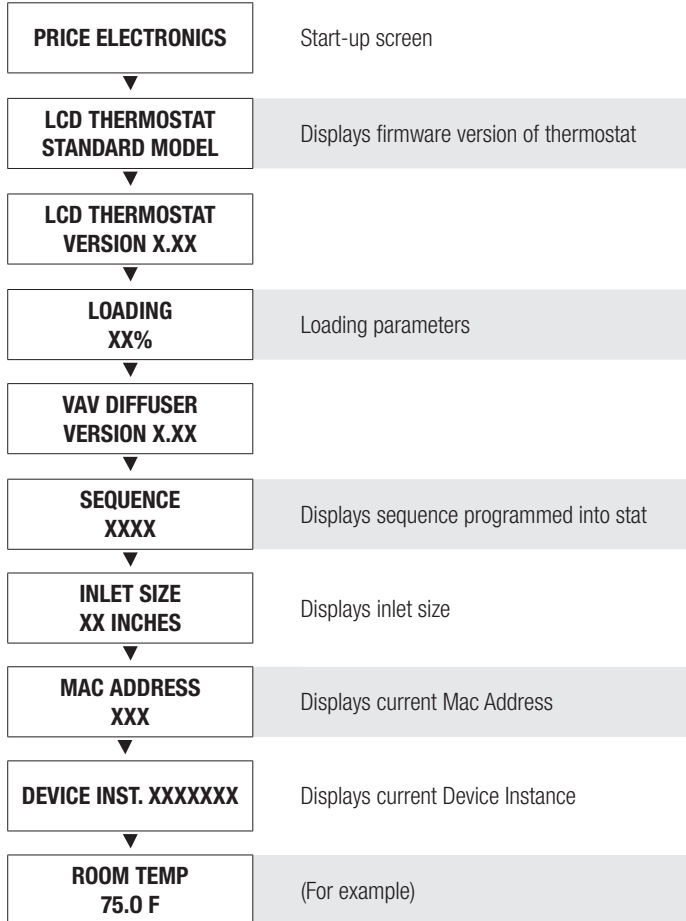

### Day Setpoint Adjustment

Increase and decrease push buttons for day set point adjustment

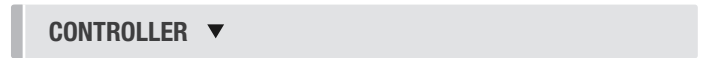

DAY SETPOINT  
75.0° F

DAY SETPOINT  
SAVING...





# PRODIGY® - DIGITAL VAV DIFFUSERS

## DISPLAY NAVIGATION

### Information Menu *LCD Stats Only*

The info menu shows information about the controller status regarding room load, damper position and BACnet address info. No values can be changed from this menu and it is not locked or protected in any way.

The **Info Menu** is accessed by pressing the **Menu** button, scroll through with **Up** and **Down** buttons.

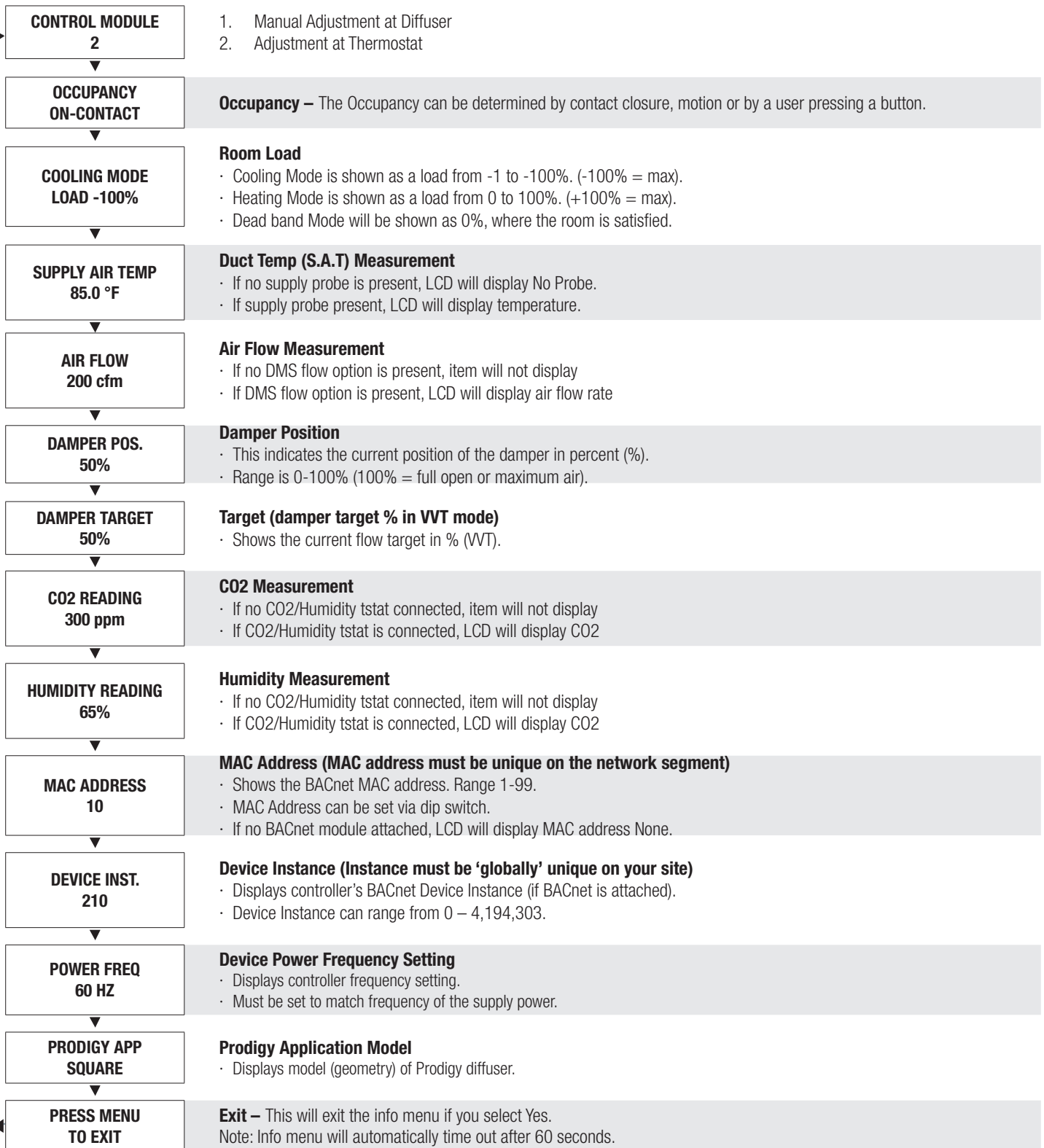

# PRODIGY® - DIGITAL VAV DIFFUSERS

## DISPLAY NAVIGATION

### Service Menu

LCD Stats Only

The **Service Menu** allows the balancer/installer to access to the controller setup to change settings. For example setting flows, heating outputs, etc.

Hold down **Menu** button for 5 seconds; display will show '**Passcode:**' Use the **Up** and **Down** buttons to enter the password in this sequence: **Down, Up, Up, Down**

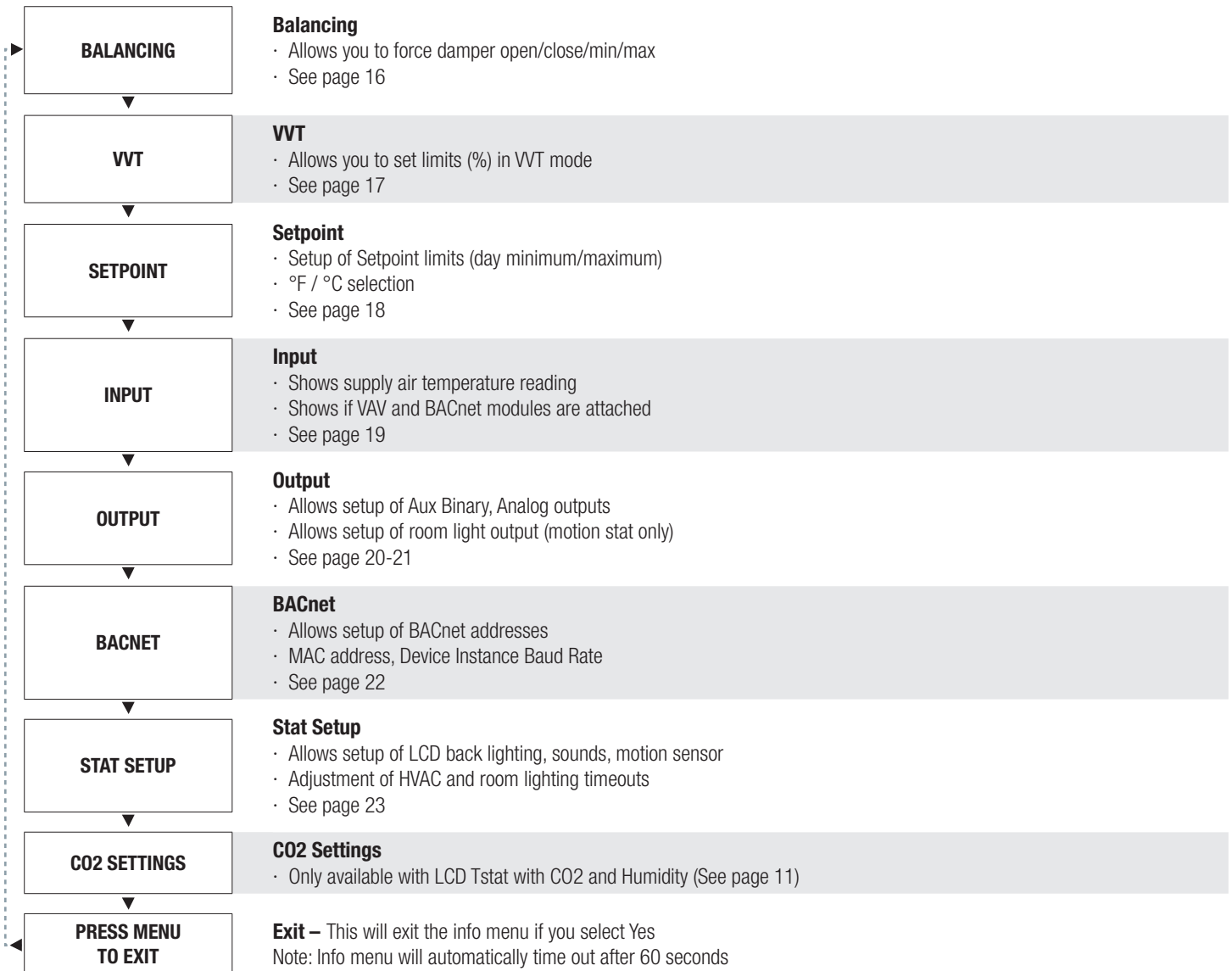

# PRODIGY® - DIGITAL VAV DIFFUSERS

## DISPLAY NAVIGATION

### Balancing Menu

Scroll through with **Up** and **Down** buttons, press **Menu** button to apply your changes \*---wait---\* will display as changes are applied.

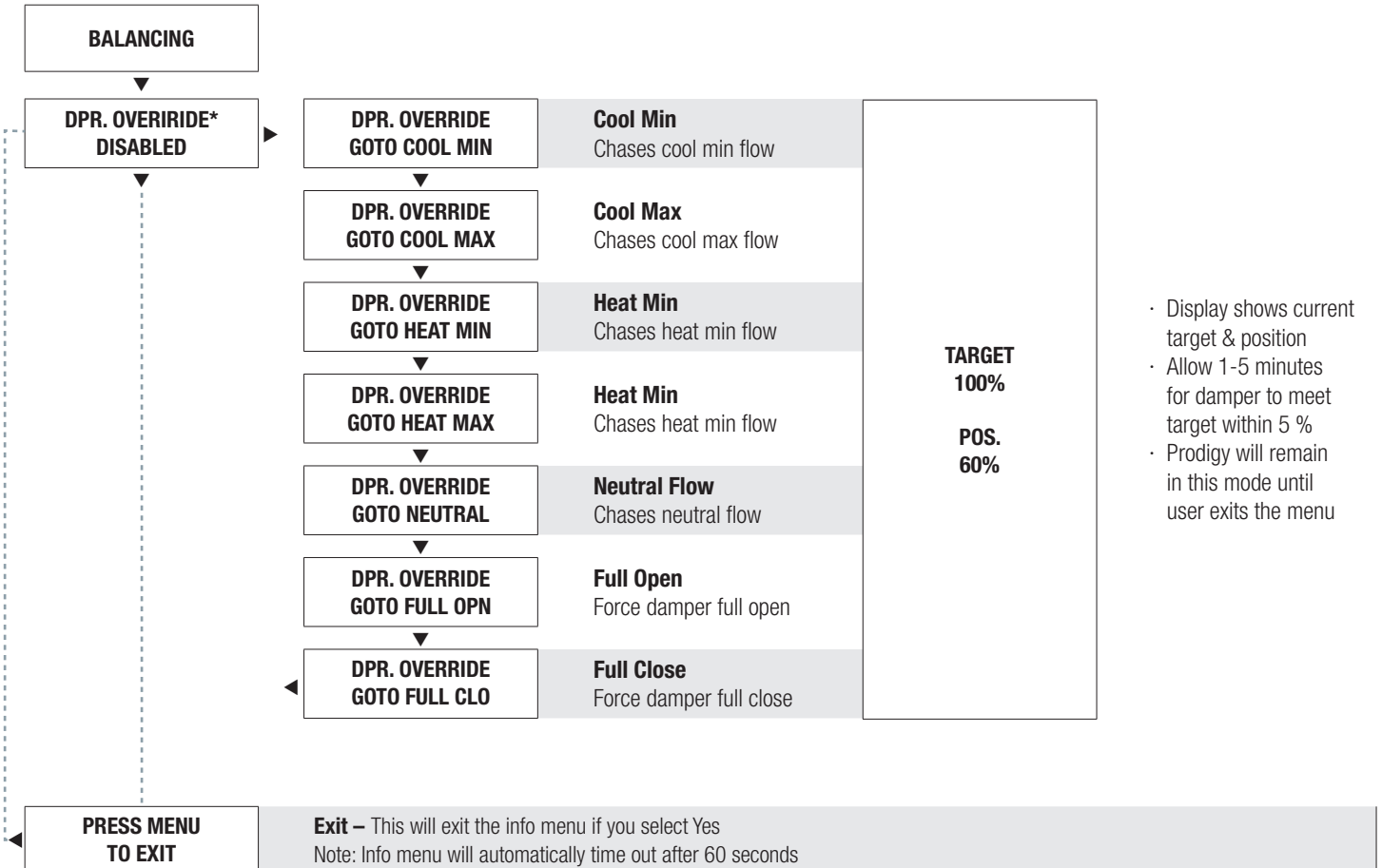

\*Also available over BACnet network if diffuser has BACnet option installed.

### TECH TIP ▼

VAV diffusers are balanced in the full open position. Use the >BALANCING >DPR. OVERRIDE >GOTO FULL OPN to open the diffuser. Remember to release the override when balancing is complete.

# PRODIGY® - DIGITAL VAV DIFFUSERS

## DISPLAY NAVIGATION

### VVT Menu

Pressure Dependent Mode

Scroll through with **Up** and **Down** buttons, press **Menu** button to apply your changes \*---wait---\* will display as changes are applied.

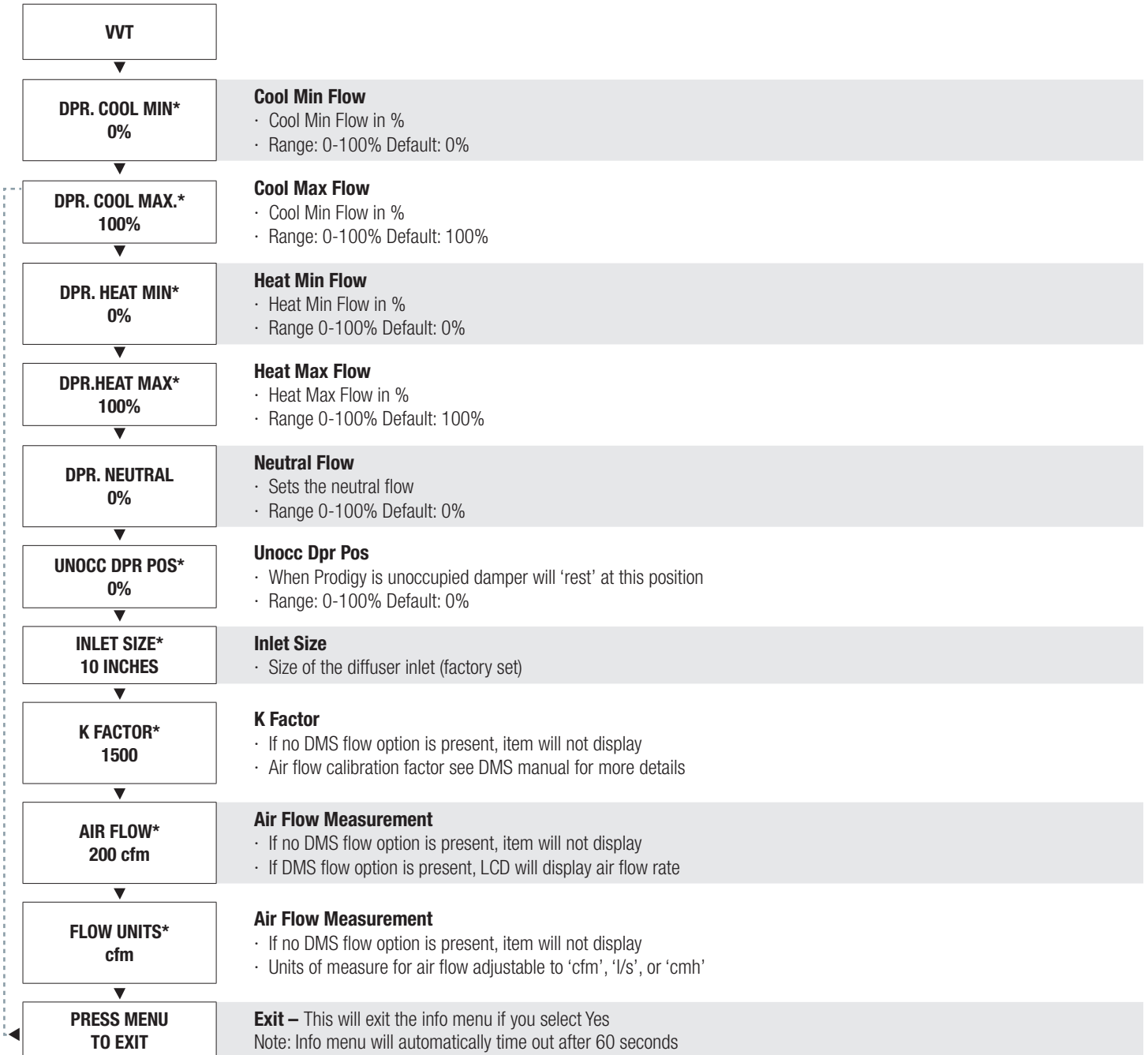

\*Also available over BACnet network if diffuser has BACnet option installed.

# PRODIGY® - DIGITAL VAV DIFFUSERS

## DISPLAY NAVIGATION

### Setpoint Menu

#### Setpoint Limits and Temperature Units

Scroll through with **Up** and **Down** buttons, press **Menu** button to apply your changes \*---wait---\* will display as changes are applied.

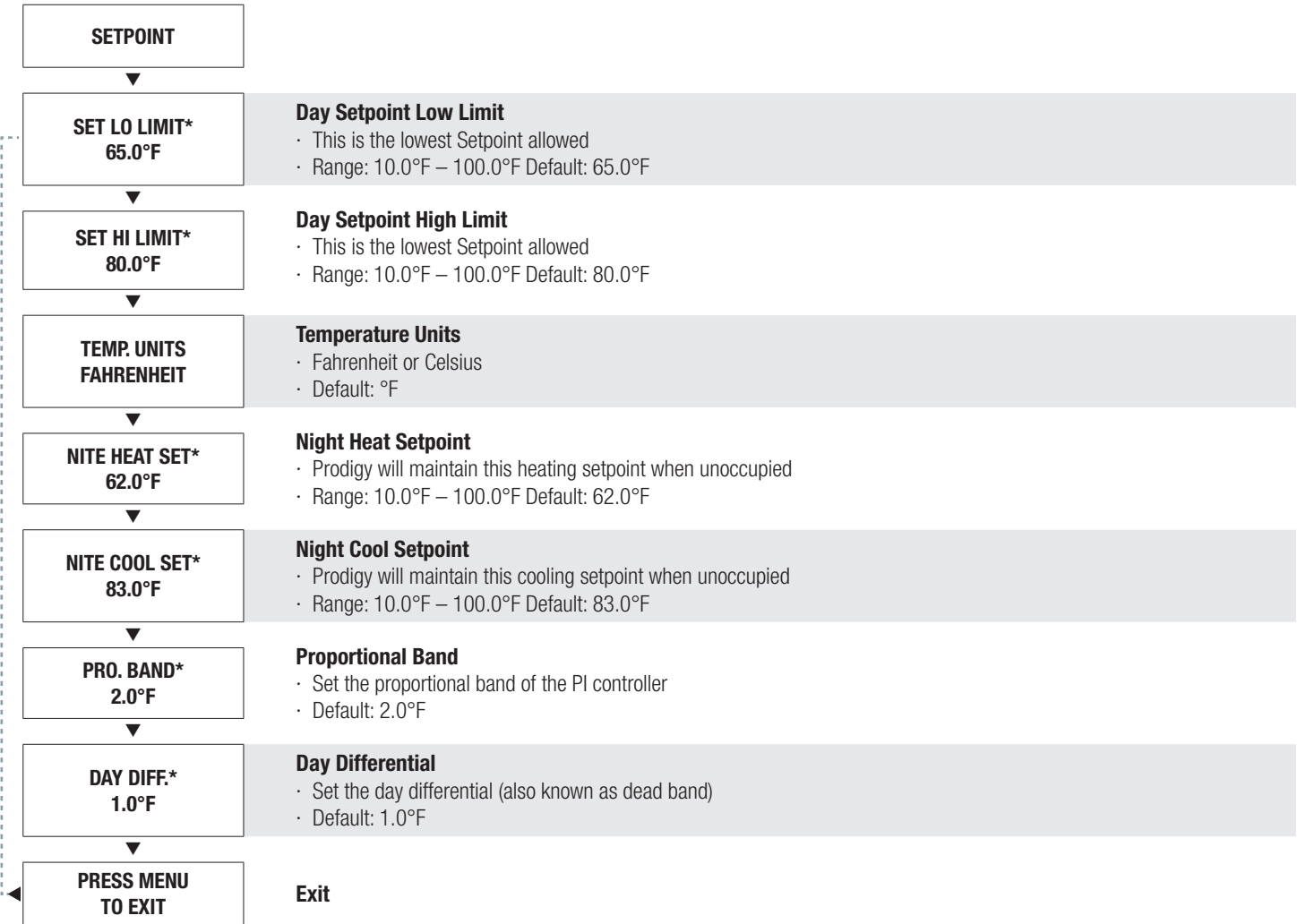

\*Also available over BACnet network if diffuser has BACnet option installed.

# PRODIGY® - DIGITAL VAV DIFFUSERS

## DISPLAY NAVIGATION

### Input Menu

#### Supply Air Temp and Neutral Mode

Scroll through with **Up** and **Down** buttons, press **Menu** button to apply your changes \*---wait---\* will display as changes are applied.

SERVICE MENU INPUT	
SUPPLY AIR TEMP 50.0°F	<b>Supply Air Temperature (SAT) readout</b> <ul style="list-style-type: none"> <li>Shows current SAT reading.</li> <li>Range: -59.0°F – 300.0°F.</li> <li>No probe, means no sensor is connected.</li> </ul>
NEUTRAL MODE ENABLED	<b>Neutral Mode = enabled</b> <ul style="list-style-type: none"> <li>Uses hot/cold switch points which are hard set.</li> <li>Not recommended.</li> </ul>
NEUTRAL MODE DYNAMIC	<b>Neutral Mode = Dynamic</b> <ul style="list-style-type: none"> <li>When supply air temp (SAT) is below room temp it is considered cooling.</li> <li>When supply air temp (SAT) is above room temp it is considered heating.</li> <li>This mode is recommended because Prodigy will always use the supply air if it can help satisfy the room load.</li> </ul> <b>Neutral Mode = Conventional</b> <ul style="list-style-type: none"> <li>Uses fixed supply air temp (SAT) to switch to cooling and heating</li> <li>Hot Switch - set SAT temperature to enable heating</li> <li>Cold Switch - set SAT temperature to enable cooling</li> </ul> <b>Neutral Mode = Force Cool</b> <ul style="list-style-type: none"> <li>Locks the diffuser in the cooling mode</li> </ul> <b>Neutral Mode = Force Heat</b> <ul style="list-style-type: none"> <li>Locks the diffuser in the heating mode</li> </ul>
RM.TM.OFFSET 0.0°F	<b>Plaque Temperature Offset</b> <ul style="list-style-type: none"> <li>Offsets the room temperature sensor.</li> <li>Default 0.0°F</li> </ul>
PLAQUE OFFSET 0.0°F	<b>Plaque Temperature Offset</b> <ul style="list-style-type: none"> <li>N/A</li> </ul>
SAT OFFSET 0.0°F	<b>Supply Air Temperature Offset</b> <ul style="list-style-type: none"> <li>Offset the SAT sensor</li> <li>Default 0.0°F</li> </ul>
CONTACTCL1CFG NO ACTION	<b>Configure action of contact switch(s) 1 - 4</b> <ul style="list-style-type: none"> <li>When switch closed: No Action, Unoccupied mode, Occupied mode, Damper full open, Damper full closed</li> <li>Only available if optional I/O Board installed.</li> <li>Default: No Action</li> </ul>
CO2 SENSOR NOT DETECTED	<b>Requires use of LCD Tstat with CO2 and Humidity Sensor</b> <ul style="list-style-type: none"> <li>CO2 Sensor = Detected</li> <li>CO2 Tweak = 0%</li> <li>CO2 Offset = 0% APM</li> </ul>
HUMIDITYSENS NOT DETECTED	<b>Requires use of LCD Tstat with CO2 and Humidity Sensor</b> <ul style="list-style-type: none"> <li>HumiditySens = Detected</li> <li>HumidityTweak = 0%</li> <li>HumidityOffset = 0% RH</li> </ul>
PWR FRQ 60 Hz	<b>Configure supply power frequency</b> <ul style="list-style-type: none"> <li>60 Hz or 50 Hz</li> </ul>
MOTOR SWITCH OPEN	<b>Read Only</b> <ul style="list-style-type: none"> <li>Indicates status of motor switch</li> </ul>
MOTOR SWITCH CONTACTED	<b>Read Only</b> <ul style="list-style-type: none"> <li>Indicates status of last calibration</li> </ul>
PRESS MENU TO EXIT	<b>Exit</b>

# PRODIGY® - DIGITAL VAV DIFFUSERS

## DISPLAY NAVIGATION

### Output Aux Binary Menu

Scroll through with **Up** and **Down** buttons, press **Menu** button to apply your changes \*---wait---\* will display as changes are applied

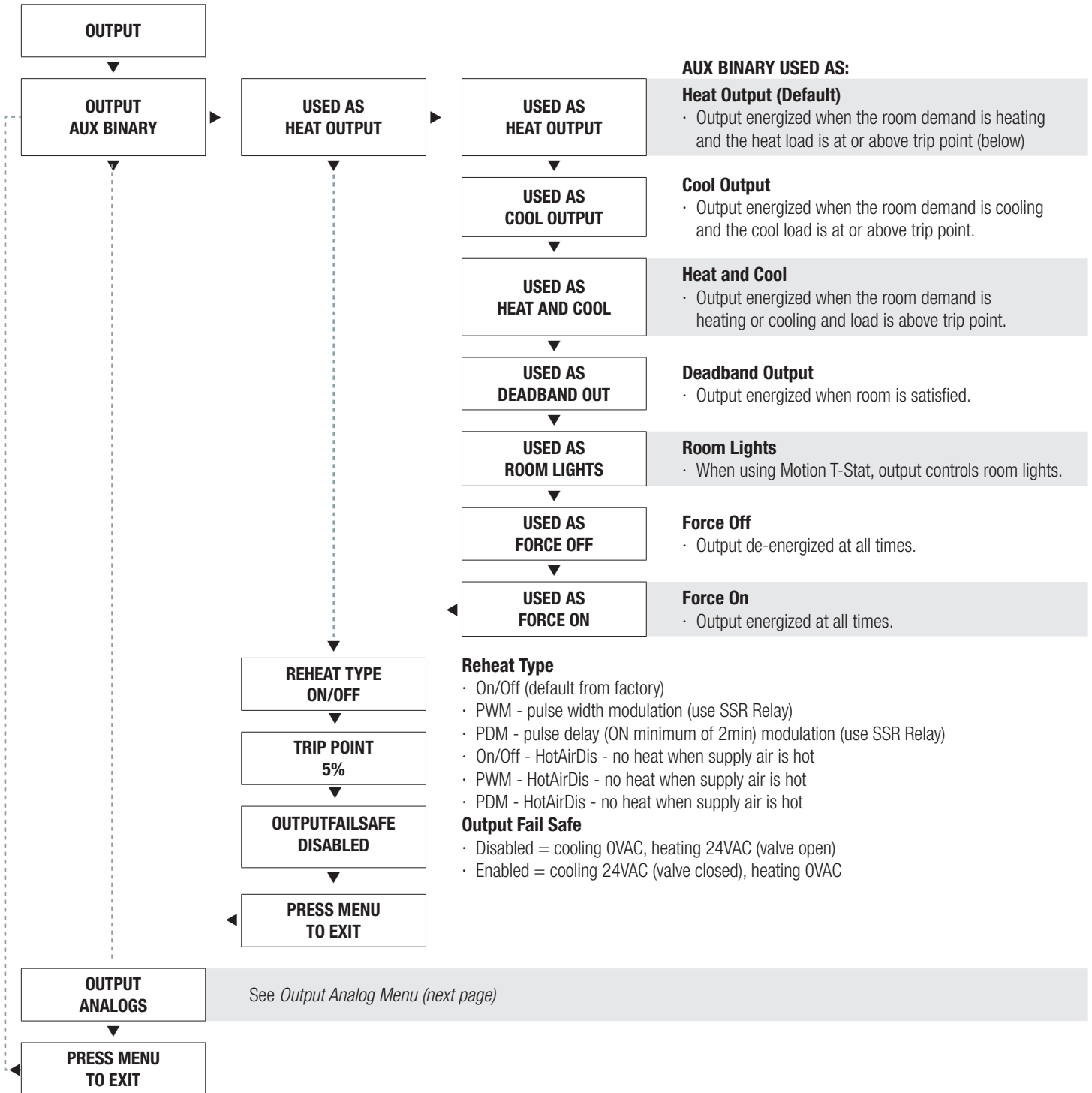

# PRODIGY® - DIGITAL VAV DIFFUSERS

## DISPLAY NAVIGATION

### Output Analog Menu

Scroll through with **Up** and **Down** buttons, press **Menu** button to apply your changes \*---wait---\* will display as changes are applied.

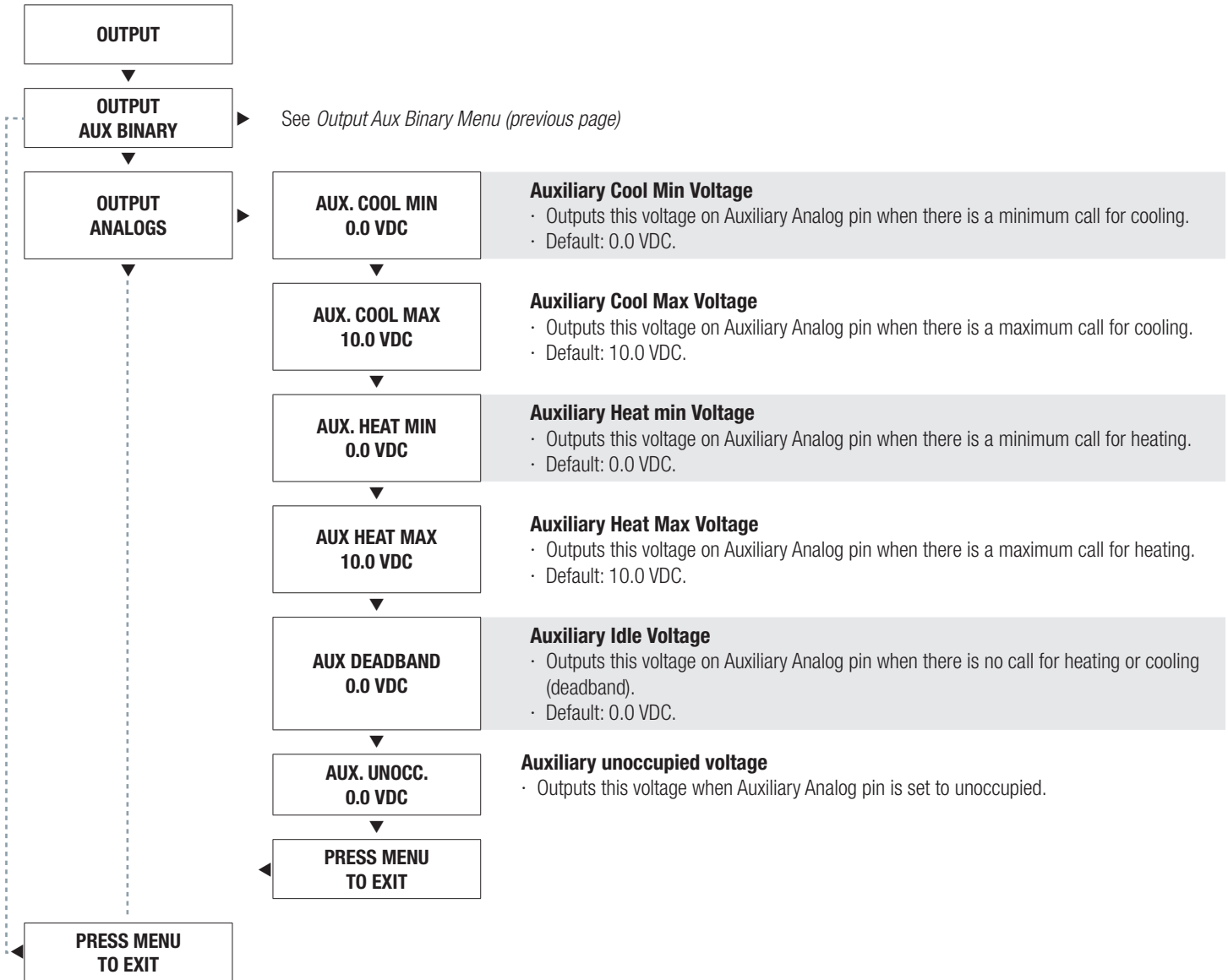



# PRODIGY® - DIGITAL VAV DIFFUSERS

## DISPLAY NAVIGATION



### BACnet Menu

#### BACnet Addressing Setup

Scroll through with **Up** and **Down** buttons, press **Menu** button to apply your changes \*---wait---\* will display as changes are applied.

**BACNET**

**MAC SET IN:  
HARDWARE**

#### MAC address

- Hardware – uses DIP switch on BACnet module for MAC address – default - recommended.
- Software – uses STAT to set MAC address – this OVERRIDES the hardware switches and could be confusing if you're not careful.
- Note: the MAC address (range 1-99) is added to the device instance.
- Example: MAC address = 1, Device instance = 100 – total address for this Prodigy would be 101.

**MAC ADDRESS  
HARDWARE: 1**

#### MAC address

- Display current MAC address.
- Note: DIP switches and software MAC address are only read on startup! See Device Instance below and Addressing on page 29-30.

**DEVICE INST.  
101**

#### Device Instance

- This is the 'software' BACnet address & MUST be unique on your building site.
- Range: 1 – 4,194,303.
- Note: After changing device instance the STAT will send a RESET command to the Prodigy to apply the ADDRESS changes. Addresses are only READ on startup, so after any changes you must reset the controller either via STAT (which is automatic) or cycle 24 VACpower.
- Note: Addresses are only read on startup to prevent a controller with faulty damaged/improperly set DIP switches from popping up all over a network, which would be extremely difficult to troubleshoot.
- See MAC address above and Addressing on page 29-30.

**BAUD RATE  
76800**

#### Baud Rate

- This sets the BACnet MS/TP baud rate.
- 9600 baud (all BACnet devices must at least support at least this speed) - slowest.
- 19200 baud.
- 38400 baud.
- 76800 baud (default baud rate for PRICE products) - fastest.

**PRESS MENU  
TO EXIT**

# PRODIGY® - DIGITAL VAV DIFFUSERS

## DISPLAY NAVIGATION

### Stat Setup Menu Menu

*Thermostat set up and configuration*

Scroll through with **Up** and **Down** buttons, press **Menu** button to apply your changes \*---wait---\* will display as changes are applied.

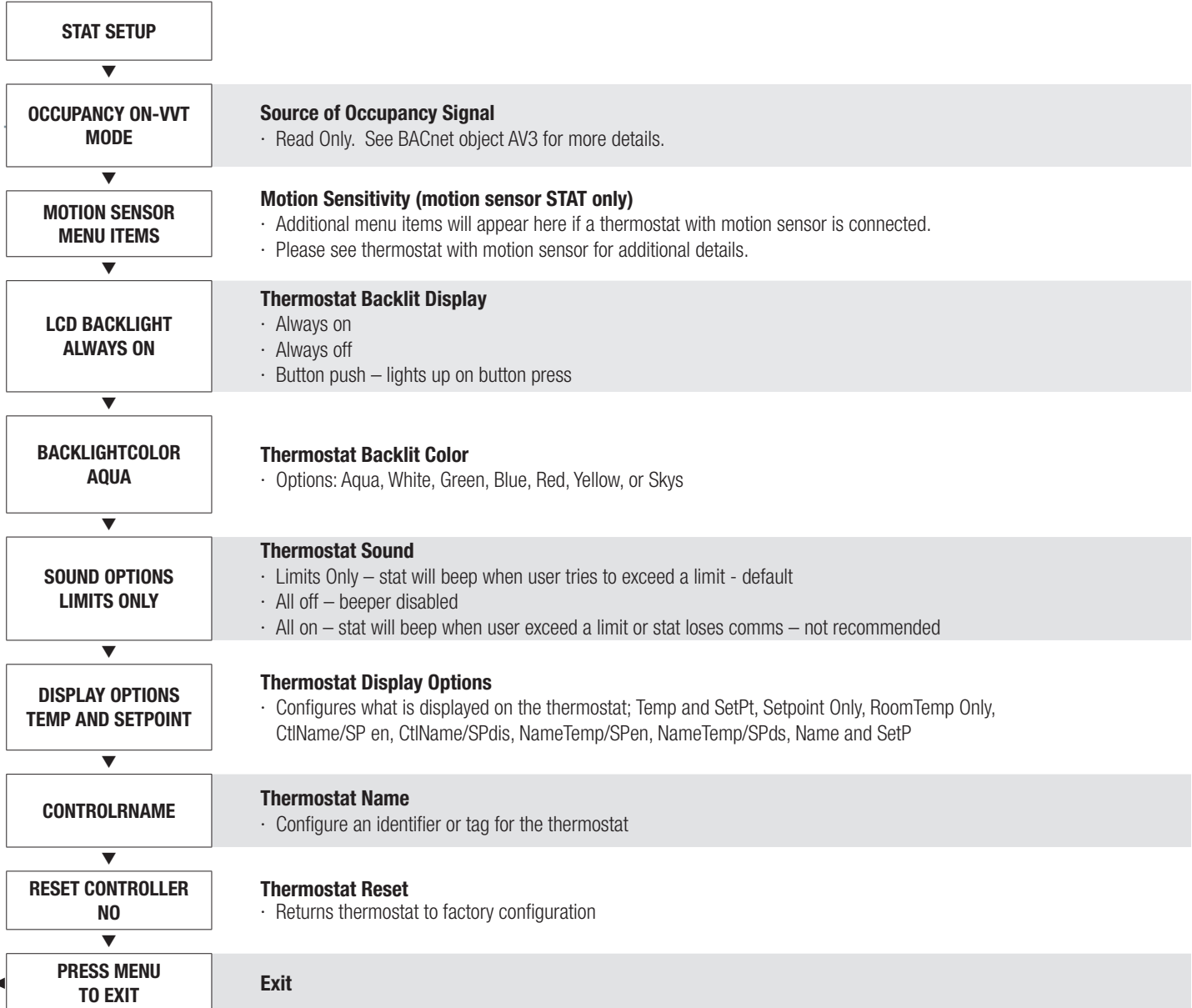

# PRODIGY® - DIGITAL VAV DIFFUSERS

---

## DISPLAY NAVIGATION

### CO2 Settings Menu

Menu item will only appear if thermostat with CO2 sensor connected. See thermostat with CO2 for more details.

### Prodigy App Menu

*Prodigy Application Model Selection*

Scroll through with **Up** and **Down** buttons, press **Menu** button to apply your changes \*---wait---\* will display as changes are applied.

PRODIGY APP

PRODIGY APP SQUARE

**Prodigy Application Model**  
· Configures for application model: Square, Round, Swirl, or Linear

PRESS MENU TO EXIT

# PRODIGY® - DIGITAL VAV DIFFUSERS

## NATIVE BACNET NETWORK INTERFACE OPTIONAL ACCESSORY

### BACnet Module

A Native BACnet communication interface is an option available for the Prodigy diffusers. Networking allows building systems, including the HVAC system to share information with each other such as set points, room temperatures, room loads and much more. Using the ASHRAE network standard BACnet allows the Prodigy to communicate with other BACnet devices. This allows interoperability between different devices even if they are made by different manufacturers.

The BACnet network interface uses the BACnet network type MS/TP (Master Slave Token Passing) which uses 2 wires in a daisy chain configuration. This network type is based RS-485 physical layer and is very robust in industrial environments while being economical enough to be implemented on each device.

The network connection between Prodigy® (with BACnet option) diffusers is done with the included plenum rated network cable. No tools needed!

Connecting the Prodigy® diffusers with the BACnet interface option is very simple and efficient. Dual RJ-45 jacks on each diffuser allow daisy chaining each device without splitters or any tools. Included with each Prodigy diffuser is a 35 foot plenum rated network cable to simplify installation in the field.

Local addresses can be set at each Prodigy® diffuser using the on-board DIP switches. The media access control (MAC) address range is 1-99. Each device on the network segment must have a unique address, otherwise communication errors will occur.

To show proper data exchange TX (transmit) and RX (receive) LEDs indicate when data is being sent and received. This provides a visual check of how the network is performing. For example if the RX LED is not blinking this could indicate a cable is unplugged at the other end, or the address is incorrect.

Standard baud rates for the BACnet MS/TP network are 9600, 19200, 38400 and 76800. All devices on the network segment must be set to communicate at the same speed. Otherwise communication errors will occur.

### Prodigy® Control Variables

There are several control variables that can be monitored and/or adjusted via the network. These include, but are not limited to:

- Room Temperature
- Room Set point
- Supply Air Temperature

- Supply Air Temperature switch over points (hot/cold/neutral temperatures)
- Inlet Size
- Reheat Type
- Damper Position
- Damper Target
- Model Type
- Ping (Sounds the Prodigy beeper helping you locate the unit)
- Day/Night Mode
- Cooling/Heating Load (100% auto + 100%)

These variables allow the user to determine the current status of a zone. This information can also be relayed to a main controller allowing it to calculate the total heating or cooling loads.

# PRODIGY® - DIGITAL VAV DIFFUSERS

## NATIVE BACNET NETWORK INTERFACE OPTIONAL ACCESSORY

### BACnet Wiring

Price Prodigy Diffusers, when selected with the optional BACnet interface, have the option of using supplied 35' CAT 5 cables to run BACnet MS/TP, or field supplied cable hardwired into

a pluggable terminal block (see next page if using hardwired BACnet connections). The RJ-45 jacks for use with the supplied BACnet cables are directly tied to the pluggable terminal block, and so any combination of supplied cables and hardwired connections can be used on a single network segment.

BACnet networks must be run in a daisy chain configuration, meaning there is only one main cable and each network device is connected directly along its path, with no more than 30 devices per segment, and MS/TP segment lengths must not exceed 1 050 feet.

### Termination

BACnet MS/TP networks must be terminated to ensure proper operation. A network should be terminated twice, once at the beginning and once at the end. Termination helps reduce reflections and noise. The terminating can be done with a 100 ohm resistor across the + and - lines. Prodigy Diffusers have the option for enabling termination via a DIP switch or by a software menu selection. Turning on termination via software will enable the resistor across the lines and also turn on a green LED labeled "TRM".

**Tech Tip:** The Price BACnet MS/TP to IP Router has built in termination and it is enabled by default (since the router is typically the beginning of the entire MS/TP network). Now you only have to go and find/terminate that last device.

### Electrical Noise

Electrical noise can affect both analog signal and digital communications such as BACnet. Therefore do not route high voltage lines next to the BACnet network! Avoid noisy electrical sources such as:

- Variable Frequency Drives
- High current power lines (main panel feeds)
- Fluorescent light fixtures

If you must pass near noisy electrical lines cross at right angles. This will help reduce the amount of noise coupled to the network wires.

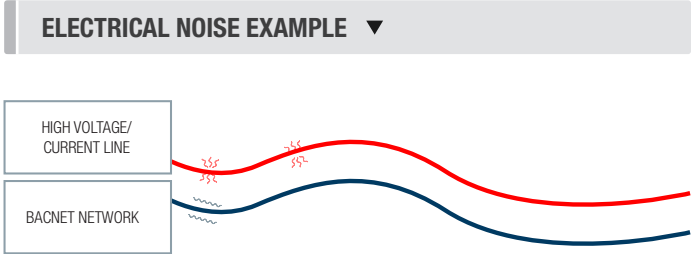
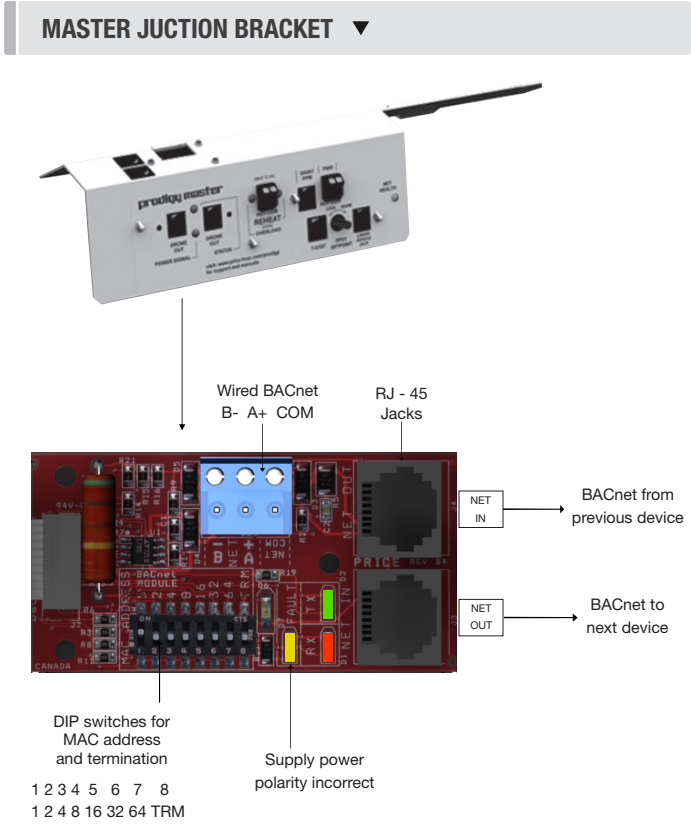

# PRODIGY® - DIGITAL VAV DIFFUSERS

## NATIVE BACNET NETWORK INTERFACE OPTIONAL ACCESSORY

Use Price supplied CAT-5 cables for BACnet whenever possible. If not possible to use Price supplied cables, follow these wire specifications.







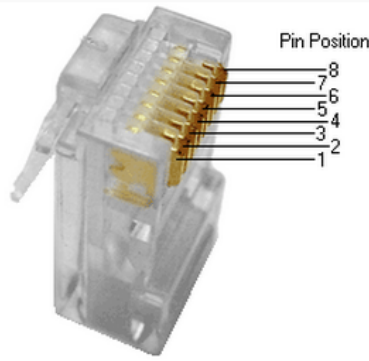

### Network Wire Specifications

For the BACnet MS/TP network specific wire is required. Do not use standard power or “thermostat” wire. This wire does not have the necessary requirements for digital communications. While it’s possible it may work (temporarily) the network will be unreliable and not operating at optimal performance.

### BACnet MS/TP Wire type recommendations

- Use 2 balanced twisted pairs, one for+ and -, one for NET COM (Twisted pair and reference or 3-conductor)
- Low capacitance (17pF or less)
- Plenum rated (FT6, CMP ratings)
- 100-120 ohm, Balanced
- (CAT5, CAT5E, CAT6 network cable has excellent specifications and will work in almost any BACnet MS/TP application.)
- **Price controllers use the Orange Compliment for(+), the Orange for(-), and the Brown and Brown Compliment together for the (NET COM) connections. These are paired in a standard CAT5E cable. Pre-terminated CAT5 cables are available from Price. Model code: NETC35 (35 ft plenum rated cable, terminated with RJ45 plugs, 568-B standard)**

**WIRING** ▼

	T568B Color	Pins on plug face (socket is reversed)
<b>PIN 1</b>	 white/orange stripe	
<b>PIN 2</b>	 orange solid	
<b>PIN 3</b>	 white/green stripe	
<b>PIN 4</b>	 blue solid	
<b>PIN 5</b>	 white/blue stripe	
<b>PIN 6</b>	 green solid	
<b>PIN 7</b>	 white/brown stripe	
<b>PIN 8</b>	 brown solid	

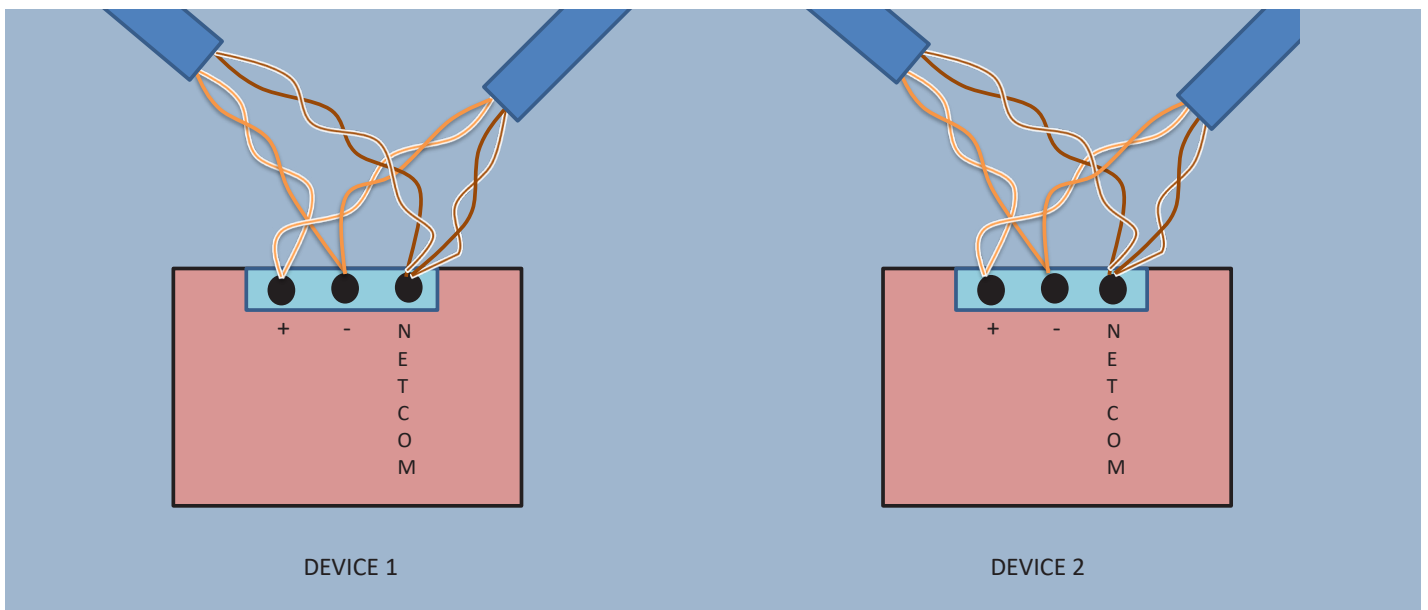

# PRODIGY® - DIGITAL VAV DIFFUSERS

## NATIVE BACNET NETWORK INTERFACE OPTIONAL ACCESSORY

### BACnet Service Menu

Each controller's MAC address, Device Instance, and Baud rate are set in the BACnet sub-menu of the service menu accessed through an LCD thermostat or LCD setup tool. For information on how to select a MAC address and Device instance for any controller on a network, see following pages.

To set the controller's BACnet settings, enter the Service Menu and adjust settings as follows:

**NOTE:** When the screen displays a flashing value, that value is ready to be changed and can be adjusted by pressing the arrow keys. Pressing Menu will save the value.



### BACnet Service Menu

Hold down the **Menu** button on the LCD Thermostat for 5 **seconds** until prompted for a passcode; use and to enter the passcode; **DOWN, UP, UP, DOWN**.

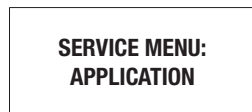

THEN



THEN



THEN



The screen will now display "Service Menu: Application."

Scroll down to the BACnet sub-menu.

Press the **Menu** button to enter this menu.

Screen will now show 'MAC set in Hardware', this is a default setting that means the physical DIP switched on the BACnet board must be set to set the MAC address. For easier setup, Price recommends setting the MAC over software which will override the DIP switch settings.

Use the up arrow to scroll to whatever MAC you are intending to set this controller to, once you arrive at the number, press Menu to save.



THEN



By default, the MAC address will appear as the last 2 digits of the device instance.

# PRODIGY® - DIGITAL VAV DIFFUSERS

## NATIVE BACNET NETWORK INTERFACE OPTIONAL ACCESSORY

DEVICE INST.  
101

THEN



OR



BAUD RATE  
76800

THEN



OR



### BACnet Service Menu

The device instance defaults to 100, but will be displayed with the last 2 digits as the MAC. Press Menu then use the arrow keys to change the device instance.

**NOTE:** Each Menu press will change allow changes in different tiers of the device instance (so that you don't have to scroll for extended periods to get into the millions range - supposing that's where you need to set your device instance)

The baud rate is the speed that the MS/TP network runs at. EVERY device on the network must run at the same speed. Price controllers are defaulted to a baud rate of 76800, but can be changed to 38400, 19200, or 9600. For a network segment with all Price controllers (including Price PRTU systems), it's recommended that the baud rate be left at 76800.

\*Choose lower baud rates only when integrating with devices by other manufacturers whose maximum speed is lower than 76800 (eg. 38400).

Once all settings are made, scroll down to press Menu to exit, and press Menu. The controller will then re-start, this is because all BACnet info is only read once at startup. If you had left the MAC set in hardware, and adjusted the DIP switch settings to set the MAC address, you would have to manually restart the controller by cycling 24 VAC power for the new MAC address to take effect (setting through software makes the restart happen automatically however).

## BACnet Networking and Setup

### Setting the MAC Address

MAC (media access control) must be UNIQUE on an MS/TP network segment within building. An installer setting up an MS/TP segment must ensure each device has a UNIQUE MAC Address (range 1-99). The MAC Address is set through the dip switches or through the LCD thermostat (or LCD Setup Tool).

**NOTE:** Each device on a MS/TP segment must be set to run at the same speed or baud rate.



### TECH TIP ▼

24 VAC power HOT and COMMON polarities are critical and must not be reversed on ANY devices! Reverse polarity will stop communication on that MS/TP segment. All 24 VAC transformers must be grounded on their secondary side for BACnet to work.

NET COM wire must be connected at each device and is critical for BACnet network reliability.

Use one twisted pair for+ and-, and another twisted pair for NET COM for optimal noise cancellation.



# PRODIGY® - DIGITAL VAV DIFFUSERS

## NATIVE BACNET NETWORK INTERFACE OPTIONAL ACCESSORY

### Setting the Device Instance (Coupled MAC and DI)

#### Device Instance:

A Device Instance number identifies a device within an entire building, therefore giving it a unique number or Address, much like a telephone ext. number. A building can have one telephone number, but all the extensions have a unique number to identify them. A Device Instance number would work the same way and must be unique throughout the building. The Device Instance number is user set through the LCD Thermostat or LCD setup tool.

Below is a table defining how a Device Instance number is obtained.

**NOTE:** Each device on a network segment must be set to run at the same speed or baud rate.

Description	Default Value (Factory)	Notes
Mac Address	6	Value: limited to 1-99
Tier 1 (x100)	58	Value: limited to 0-99
Tier 2 (x10,000)	1	Value: limited to 0-99
Tier 3 (x1,000,000)	0	Value: limited to 0-4

### Example Device Instance Setup with Default Settings:

MMAC Address = 6 (6 x 1 = 6) - Set through software

+

TIER 1 = 58 (58 x 100 = 5800) - Set through software

+

TIER 2 = 1 (1 x 10,000 = 10,000) - Set through software

+

TIER 3 = 0 (0 x 1,000,000 = 1,000,000) - Set through software

=

Final Device Instance = 0 01 58 06  
Tier 3 Multiplier Tier 2 Multiplier Tier 1 Multiplier MAC Multiplier

#### LCD SETUP ▼



### TECH TIP ▼

When using a DIAL thermostat, you must purchase a setup tool LCD-SETUP and use this to configure the Prodigy diffuser. Remember, all settings are stored in the Prodigy diffuser and not the thermostat.

# PRODIGY® - DIGITAL VAV DIFFUSERS

## MAINTENANCE

### Troubleshooting Guide

The following information is provided in the event that a Prodigy diffuser does not appear to function properly after installation. Since all master units are auto-changeover controllers, response will be dependent on the supply air temperature. Connected drone units will synchronize damper position with master unit.

Please note that the maximum damper opening position is specific to the Prodigy model and inlet size. The full open position is different by model and inlet size to ensure discharge velocity is maintained. When comparing the full open position between diffusers check the diffuser model and inlet size as these will affect the full open position.

Supply Air Temperature	Test Procedure	Prodigy Response (Response Time Varies allow at least 5 minutes)
COLD Supply Air Temperature 2°F (1°C) cooler than Room Temperature	<b>Adjust setpoint for maximum cooling</b> ADV– with Thermostat Adjustment - setpoint dial.	Damper moves towards maximum air flow position <i>provided room temperature is not below setpoint.</i>
	<b>Adjust setpoint for minimum cooling</b> ADV– with Thermostat Adjustment - setpoint dial.	Damper moves towards minimum air flow <i>position provided room temperature is not above setpoint.</i>
Neutral Supply Air Temperature within 2°F (1°C) of Room Temperature	<b>All Units</b>	Damper will move to neutral position. Default: 50%. Adjustable through LCD thermostat.
HOT Supply Air Temperature 2°F (1°C) warmer than Room Temperature	<b>Adjust setpoint for minimum heating</b> ADV – setpoint dial.	Damper moves towards minimum air flow position provided room temperature is not below setpoint.
	<b>Adjust setpoint for maximum heating</b> ADV – setpoint dial.	Damper moves towards maximum air flow position provided room temperature is not above setpoint.

If the Master diffuser damper appears to be about 1/2 open and does not move from this position, check the 'Damper Pos' in the 'Info Menu' or 'Service Menu'. If 'Motor Switch Err' is displayed then please contact the factory for instructions.

(Note - This error does not affect any Drones connected to the Master.)

Status LED's are provided on the Junction Panel of all Prodigy Diffusers to aid in field diagnostics. Green LED – Indicates presence of 24 VAC power supply. Red LED – Indicates presence of 2 - 10 VDC Drone Signals.

Status Lights on Junction Panel			Action Required
Master	Green	Red	
No Drone Connected to Master	OFF	OFF	Unit is not receiving power. Check 24 VAC supply line and connections.
	ON	OFF	Thermal resettable fuse has tripped. Remove 24 VAC power supply for 15 seconds, then repower unit.
	ON	Flashing	Normal operation status (after initial 2 minute calibration cycle).
Drone	Green	Red	
Test One Drone at a time with Master functioning properly	OFF	OFF	No connection between Master and Drone. Check cable connections.
	ON	OFF	Drone has caused resettable fuse on master to trip. Remove 24 VAC power supply from Master for 15 seconds, then reapply power. If condition reoccurs, contact Price.
	ON	Flashing	(after initial 2 min calibration cycle) 1 Flash - poor connection between Master and Drone 2 Flashes - Normal operation closed 3 Flashes - Normal operation 4 Flashes - Normal operation open 5 Flashes - Drone motor switch error - damper should be 50% open (contact factory for instructions)

# PRODIGY® - DIGITAL VAV DIFFUSERS

## MAINTENANCE

### Troubleshooting Guide Continued...

PPM		
Condition	Possible Cause	Remedy
Green Power Light Off	Disconnect Switch Off	Turn Switch On
	Transformer Circuit Breaker Tripped	Disconnect Power. Unplug all output cables. Remove lid. Reset breaker on transformer. Replace Lid. Reconnect Power. Reconnect all plugs one at a time.
	No Power Supply	Check Line Connections.
Red Fault Light On above Output Jack	Too many Prodigy Units or Heat Relays supported on Line	Reroute some power cables to another jack.
	Faulty Cable or Connector	First - Disconnect all cables and connectors originating from problem outlet. Next - Reconnect first C35 cable only. If Red fault LED lights, cable is faulty. Replace. If Red fault LED remains off, reconnect remaining components (CS, CC, C35, Prodigy Masters) one at a time until LED lights. Replace faulty component.
	Redundant Power Supply	Eliminate Redundant Power Supply
Auxiliary Heat		
Red Fault LED on	Mechanical Relay draws more than 12 VA	Replace with smaller relay or electronic SSR.
Insufficient Power to mechanical relay	Cable distance from PPM exceeds 35 feet	Relocate PPM or Mechanical Relay, or use electronic SSR.

# PRODIGY® - DIGITAL VAV DIFFUSERS

## MAINTENANCE

### Prodigy Specifications

<b>Specifications</b>	Prodigy Master (PPD1, PPD2, PPD3)
<b>Power Supply</b>	24 VAC (+-10%) 60Hz; Class 2
<b>Power Consumption</b>	3 VA for diffuser (+ Prodigy Drones and any reheat load)
<b>Electrical Connection</b>	2 position pluggable terminal block OR RJ12 jack from Power Module
<b>Certification</b>	ETL listed
<b>Outputs</b>	1 Binary Triac zero crossing output at 24 VAC (thermally protected) 12VA maximum 2x RJ12 jacks for Prodigy Drone units (maximum 6 total per master)
<b>Input</b>	1x RJ45 Thermostat jack (works with Price line of thermostats and Prodigy PPD1 jumper)
<b>Communication</b>	BACnet Master MS/TP module supports 9600/19200/38400/76800 baud rates, 2x RJ45 connections, Green Transmit LED, Red Receive LED, MAC address settable through DIP switches or LCD thermostat, Device Instance settable through LCD thermostat, or LINKER service tool.
<b>Proportional Band</b>	2.0°F (or 1.0°C) cooling and heating (adjustable via LCD thermostat or LINKER service tool)
<b>Processor</b>	8-bit 128kB flash based microcontroller with EEPROM
<b>Temperature Sensors</b>	10k NTC supply air temperature thermistor, 10k NTC Thermostat thermistor
<b>Temperature Sensor Range</b>	-40°F - +175°F (-40.0°C - + 79.4°C)

### Prodigy Drone Specifications

<b>Power Supply</b>	24 VAC (+-10%) 60Hz; Class 2 (supplied by Prodigy Master via RJ12 cable (C35))
<b>Power Consumption</b>	3 VA
<b>Electrical Connection</b>	RJ12 jack
<b>Certification</b>	ETL listed
<b>Outputs</b>	2x Binary 24 VAC for Damper Motor supplied via RJ12 (C35)
<b>Input</b>	2 – 10 VDC signal (supplied by Prodigy Master)





This document contains the most current product information as of this printing. For the most up-to-date product information please go to [priceindustries.com](http://priceindustries.com), where you can also access digital brochures, CAD files, performance data and more.

---

**Contact Us!**

510 785 0510

[vavdiffusers@priceindustries.com](mailto:vavdiffusers@priceindustries.com)